

## HEATER SYSTEM

## 1990-92 Heater Systems

## DESCRIPTION &amp; OPERATION

Heater case, mounted under center of instrument panel, contains airflow mode door and air-mix (temperature blend) door. See **Fig. 1**. Blower case, mounted under right end of instrument panel, contains recirculated/fresh air door. All doors are controlled manually from control panel by cable.

Blower motor relay, in left rear corner of engine compartment (on relay cluster), supplies power to blower motor. Blower resistors, on bottom of blower case, determine blower speed.

**WARNING:** To avoid injury from accidental air bag deployment, read and carefully follow all **SERVICE PRECAUTIONS** and **DISABLING & ACTIVATING AIR BAG SYSTEM** procedures in **AIR BAG** article in the **ACCESSORIES/SAFETY EQUIPMENT** Section.

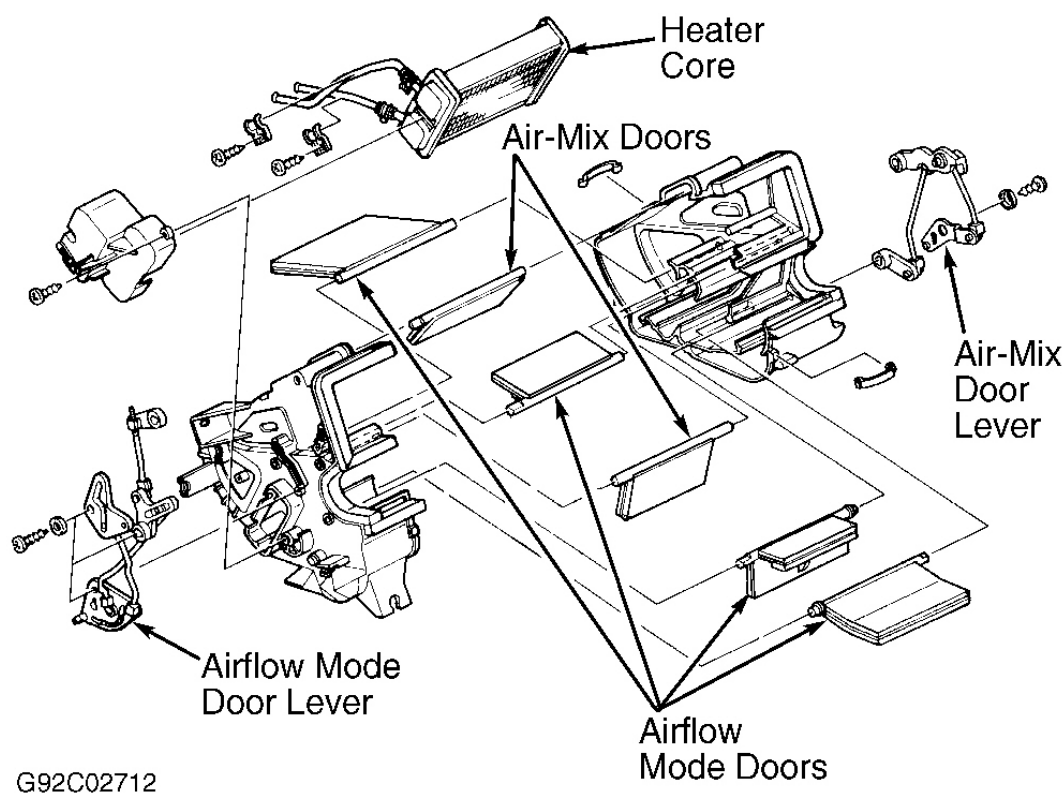

**Fig. 1: Exploded View of Heater Case**  
Courtesy of MAZDA MOTORS CORP.

## ADJUSTMENTS

### AIRFLOW MODE DOOR

Set airflow mode control lever to vent position. Disconnect control cable at airflow mode door lever. Extend airflow mode door lever until it stops, and hold it there. See **Fig. 1** . Attach control cable to door lever and clip. Ensure control lever moves freely between defrost and vent positions.

### AIR-MIX (TEMPERATURE BLEND) DOOR

Set temperature control lever to maximum hot position. Disconnect control cable at air-mix door lever. See **Fig. 1** . Extend air-mix door lever until it stops, and hold it there. Attach control cable to door lever and clip. Ensure control lever moves freely between hot and cold positions.

### RECIRCULATED/FRESH AIR DOOR

Set recirculated/fresh air control lever to fresh position. Disconnect control cable at recirculated/fresh air door lever. Retract recirculated/fresh air door lever until it stops, and hold it there. Attach control cable to door lever and clip. Ensure control lever moves freely between recirculated air and fresh air positions.

## TESTING

**WARNING:** To avoid injury from accidental air bag deployment, read and carefully follow all SERVICE PRECAUTIONS and DISABLING & ACTIVATING AIR BAG SYSTEM procedures in AIR BAG article in the ACCESSORIES/SAFETY EQUIPMENT Section.

### BLOWER MOTOR CIRCUIT

1. Check 30-amp HEATER circuit breaker in passenger compartment fuse panel. If Red button has not popped out, go to next step. If Red button has popped out, repair short circuit and press Red button to reset circuit breaker.
2. Turn ignition on. Turn blower switch to 4th position (high). Check voltage at Blue wire terminal of 2-wire blower motor connector on bottom of blower case. If no voltage is present, repair wiring between circuit breaker and blower motor.

**NOTE:** Blower resistor uses a 1-wire connector and a 4-wire connector. The wire in the 1-wire connector is Blue/Red, and one of the wires in the 4-wire connector is Blue/Red. Check voltage at appropriate wire.

3. If battery voltage is present, turn off blower switch and A/C switch (if equipped). Check voltage at Blue/Red wire terminal of blower resistor 1-wire connector. If no voltage is present, replace blower motor. If battery voltage is present, check voltage at Blue/White wire terminal of blower resistor connector.
4. If no voltage is present, replace blower resistor. If battery voltage is present, check voltage at Blue/Red

## 1991 Mazda MX-5 Miata

### HEATER SYSTEM 1990-92 Heater Systems

wire terminal of blower resistor 4-wire connector. If no voltage is present, replace blower resistor.

5. If battery voltage is present, check voltage at Blue/Green wire terminal of blower resistor connector. If no voltage is present, replace blower resistor. If battery voltage is present, check voltage at Blue/Yellow wire terminal of blower resistor connector.
6. If no voltage is present, replace blower resistor. If battery voltage is present, turn ignition on and blower switch to 4th position (high). Check voltage at Black wire terminal of blower switch connector. If battery voltage is present, repair wiring between blower switch and ground.
7. If no voltage is present, turn ignition switch, blower switch and A/C switch off. Check voltage at Blue/White wire terminal of blower switch connector. If no voltage is present, repair wiring between blower resistor and blower switch.
8. If battery voltage is present, check voltage at Blue/Red wire terminal of blower switch connector. If no voltage is present, repair wiring between blower resistor and blower switch. If battery voltage is present, check voltage at Blue/Green wire terminal of blower switch connector.
9. If no voltage is present, repair wiring between blower resistor and blower switch. If battery voltage is present, check voltage at Blue/Yellow wire terminal of blower switch connector. If battery voltage is present, replace blower switch. If no voltage is present, repair wiring between blower resistor and blower switch.

### **BLOWER MOTOR**

Disconnect 2-wire connector from bottom of blower motor case. Apply battery voltage across terminals. Replace blower motor if it does not operate.

### **BLOWER SWITCH**

With blower switch in positions indicated, check continuity between specified terminals of blower switch connector. See **Fig. 2** . If continuity is not as specified, replace blower switch.

# 1991 Mazda MX-5 Miata

## HEATER SYSTEM 1990-92 Heater Systems

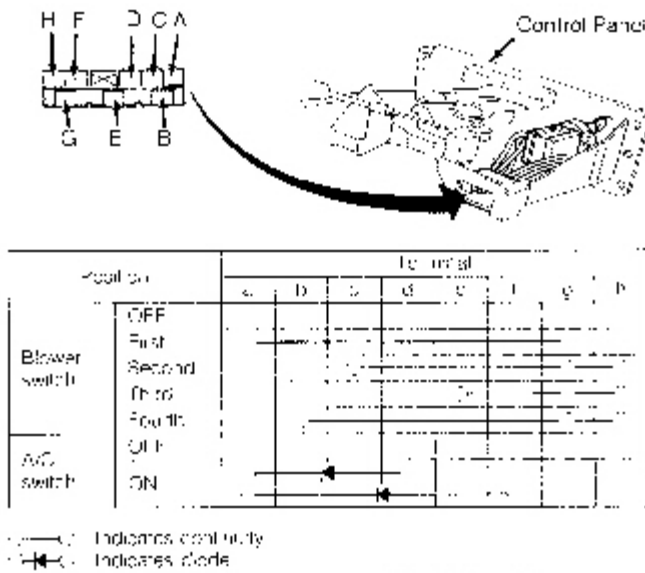

**Fig. 2: Testing Blower Switch**  
Courtesy of MAZDA MOTORS CORP.

## REMOVAL & INSTALLATION

**WARNING:** To avoid injury from accidental air bag deployment, read and carefully follow all **SERVICE PRECAUTIONS** and **DISABLING & ACTIVATING AIR BAG SYSTEM** procedures in **AIR BAG** article in the **ACCESSORIES/SAFETY EQUIPMENT** Section.

### CONTROL PANEL

#### Removal & Installation

Remove rear center console assembly. Remove vent outlets from center panel assembly. Remove center panel assembly. Remove control panel screws. Pull control panel from center panel and disconnect cables. To install, reverse removal procedure.

### HEATER CORE

#### Removal & Installation

## 1991 Mazda MX-5 Miata

### HEATER SYSTEM 1990-92 Heater Systems

Drain coolant. Disconnect heater hoses at engine compartment firewall. Remove grommets from holes (if equipped). Remove instrument panel. Remove heater case. Disassemble case and remove heater core. See **Fig. 1**. To install, reverse removal procedure. Fill cooling system.

## INSTRUMENT PANEL

### Removal & Installation

Obtain code number and deactivate audio anti-theft system. Disconnect negative battery cable. Remove all components in order listed in illustration. See **Fig. 3**. To install, reverse removal procedure.

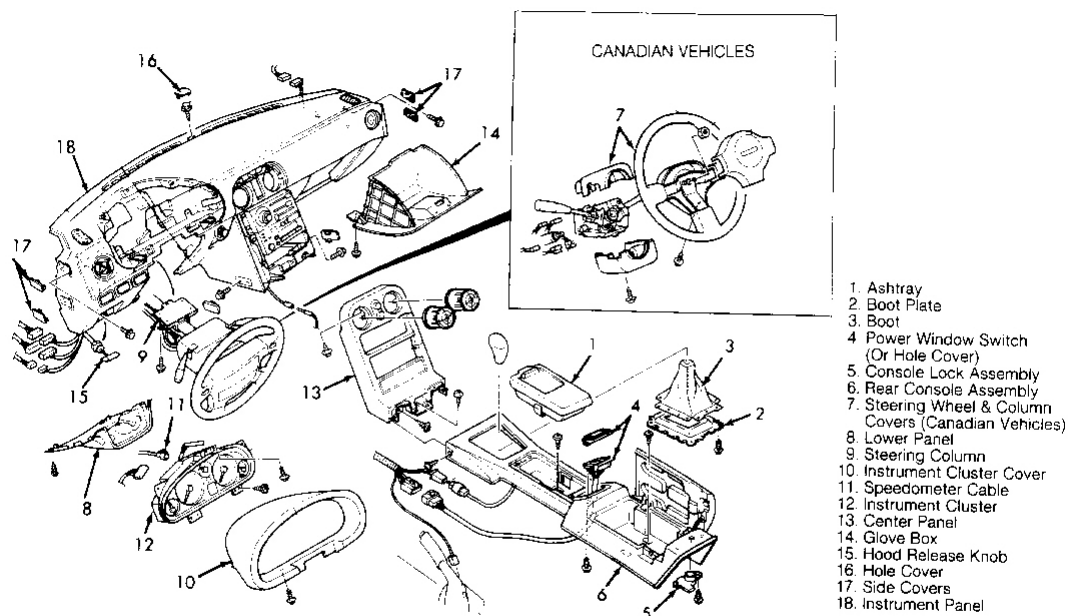

91F04864

**Fig. 3: Exploded View of Instrument Panel**  
Courtesy of MAZDA MOTORS CORP.

## WIRING DIAGRAM

# 1991 Mazda MX-5 Miata

## HEATER SYSTEM 1990-92 Heater Systems

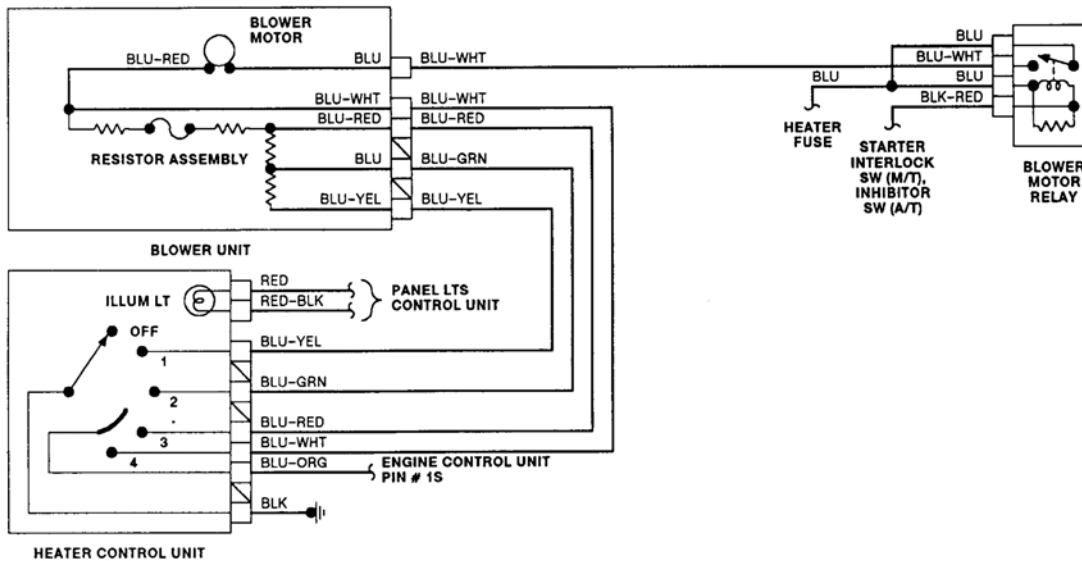

**Fig. 4: Heater System Wiring Diagram (Miata)**

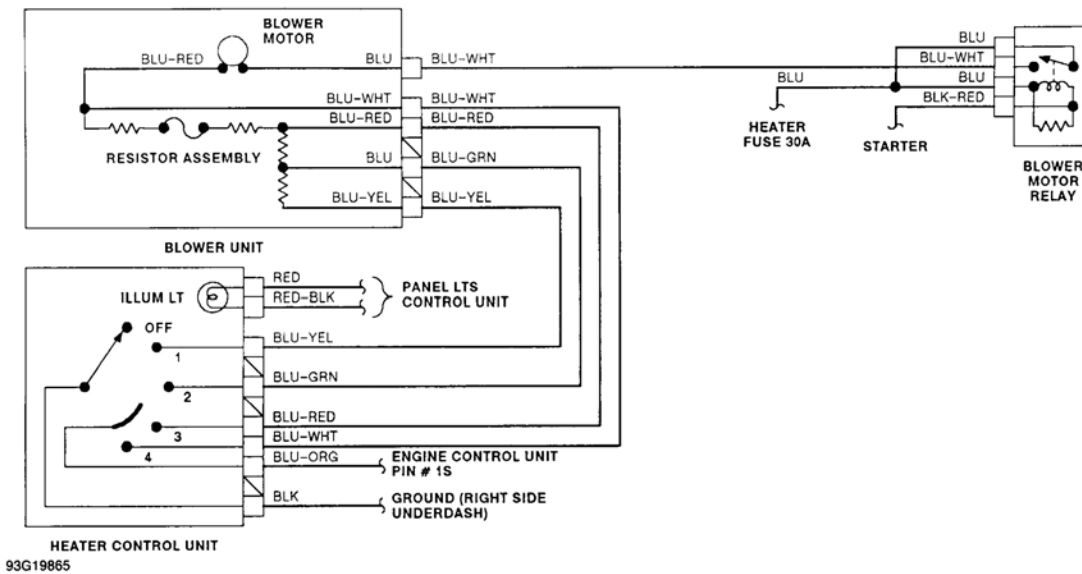

**Fig. 5: Heater System Wiring Diagram (1992 Miata)**