

2007 DRIVELINE/AXLES

Differential - MX-5 Miata

REAR DIFFERENTIAL LOCATION INDEX

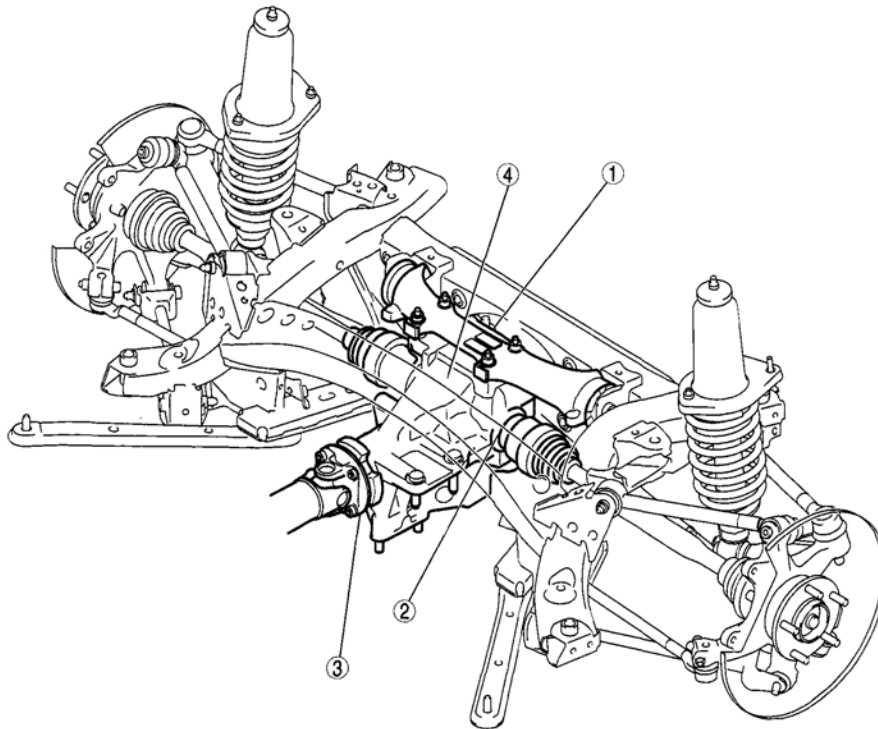

E5U314ZW5007

1	Differential oil, oil-fill plug and drain plug
2	Oil seal (side gear)

3	Oil seal (companion flange)
4	Rear differential

Fig. 1: Identifying Location Of Rear Differential Components
Courtesy of MAZDA MOTORS CORP.

DIFFERENTIAL OIL INSPECTION

1. Park the vehicle on level ground for approx. 5min. to stabilize the differential oil.
2. Remove the oil-fill plug and the washer.

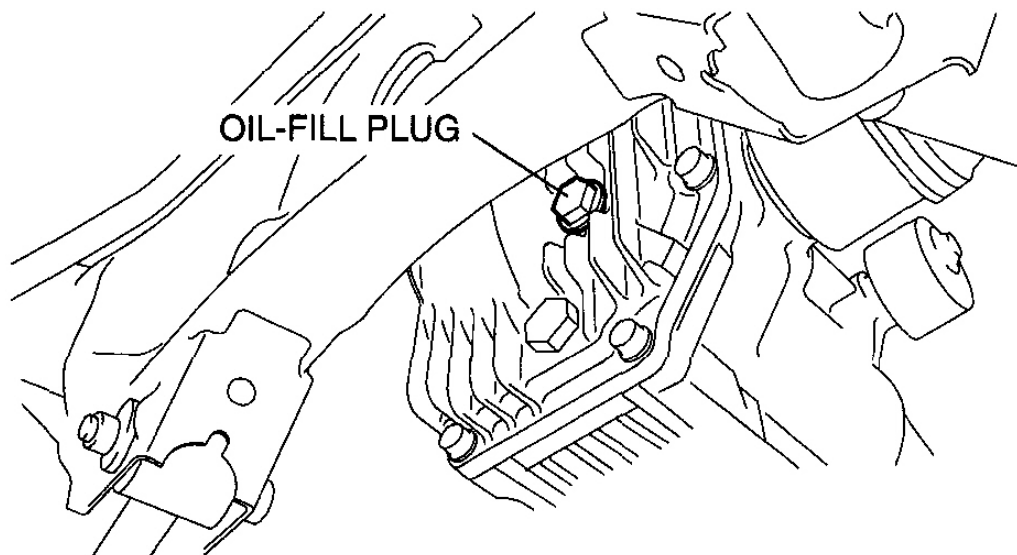

CHU0314W015

Fig. 2: Identifying Oil-Fill Plug
Courtesy of MAZDA MOTORS CORP.

3. Inspect if the oil level is close to the rim of the oil-fill plug hole.

NOTE:

- Each vehicle is filled with a specified amount of oil (0.7 +/- 0.1 L) when it is delivered, therefore, the oil level is lower than the lower end of the plug hole as shown in the figure. However, this has no affect on the differential function.

4. If the oil level is lower than approx. 12 mm {0.47 in} from the lower end of the oil-fill plug hole, inspect for oil leakage and add the specified oil.

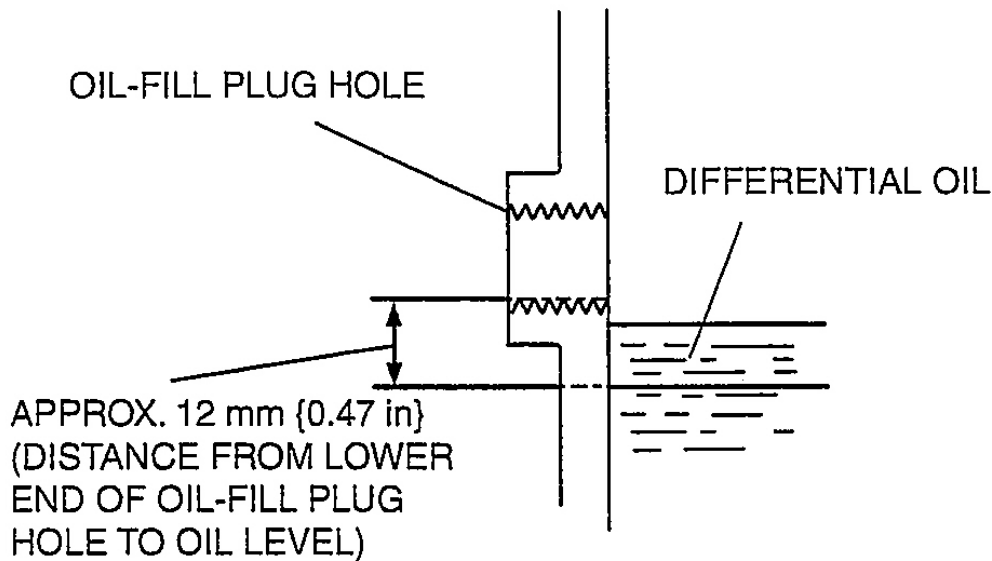

amxuuw0000051

Fig. 3: Identifying Oil Fill Level
Courtesy of MAZDA MOTORS CORP.

Differential oil

Grade: API service GL-5

Viscosity: SAE 90, SAE 80W-90, SAE 75W-90 (Not available from Mazda)

5. Install the oil-fill plug with a new washer and tighten.

Tightening torque

39.2-53.9 N.m {4.00-5.49 kgf.m, 29.0-39.7 ft.lbf}

DIFFERENTIAL OIL REPLACEMENT

1. Park the vehicle on level ground.
2. Remove the oil-fill plug.
3. Remove the drain plug and drain the oil.

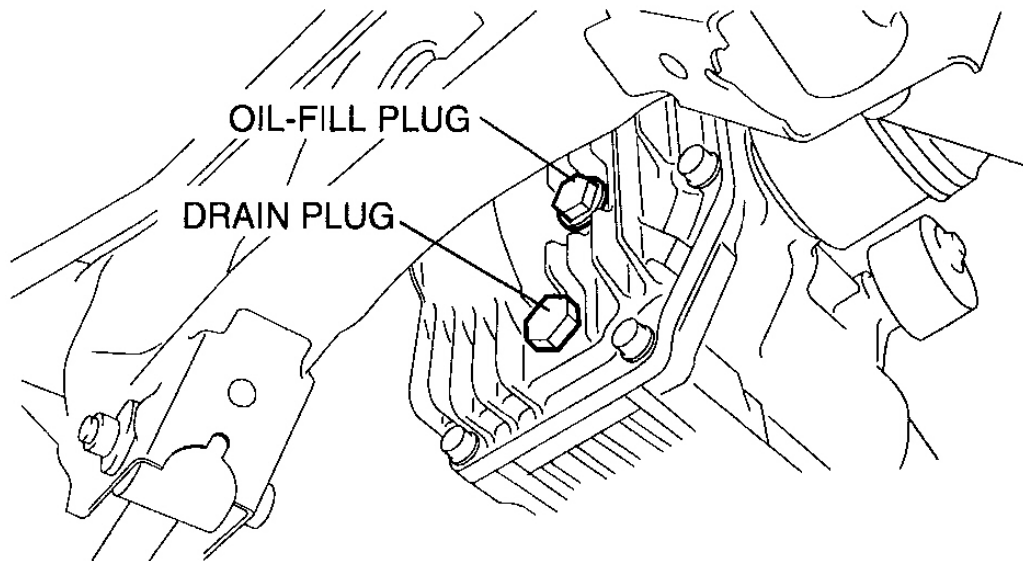

CHU0314W002

Fig. 4: Identifying Oil Fill Plug & Drain Plug
Courtesy of MAZDA MOTORS CORP.

4. Install the drain plug with a new washer and tighten.

Tightening torque

39.2-53.9 N.m

{4.00-5.49 kgf.m, 29.0-39.7 ft.lbf}

5. Add the specified oil through the oil-fill plug hole until the oil level reaches the lower end of the plug hole.

Differential oil

Grade: API service GL-5

Viscosity: SAE 90, SAE 80W-90, SAE 75W-90 (Not available from Mazda)

Capacity (approx. quantity): 0.6-0.8 L {0.63-0.85 US qt, 0.53-0.70 Imp qt}

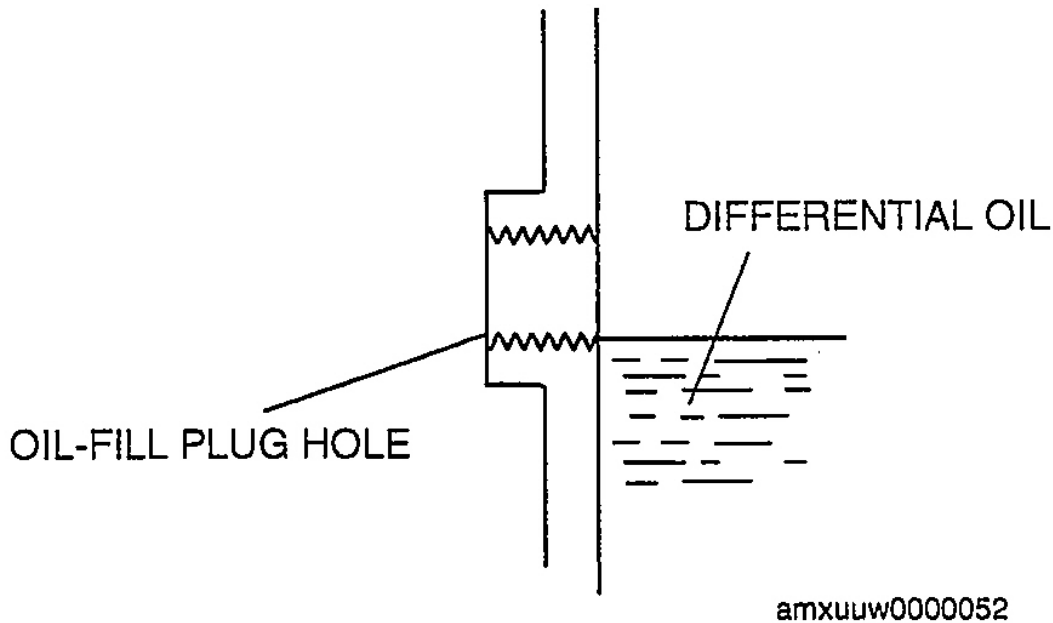

Fig. 5: Identifying Oil-Fill Plug Hole And Differential Oil
Courtesy of MAZDA MOTORS CORP.

6. Install the oil-fill plug with a new washer and tighten.

Tightening torque

39.2-53.9 N.m

{4.00-5.49 kgf.m, 29.0-39.7 ft.lbf}

OIL SEAL (SIDE GEAR) REPLACEMENT

1. Remove the drain plug and drain the oil.
2. Install the drain plug with a new washer and tighten.

Tightening torque

39.2-53.9 N.m {4.00-5.49 kgf.m, 29.0-39.7 ft.lbf}

3. Disconnect the rear drive shaft on the differential side.

(See **REAR DRIVE SHAFT, REAR KNUCKLE COMPONENT REMOVAL NOTE** .)

4. Remove the clip from the rear drive shaft.

CAUTION:

- To prevent damaging the inside of the differential casing, wrap cloth on the end of the flathead screwdriver.

5. Remove the oil seal from the differential carrier using a flathead screwdriver.
6. Apply differential oil to the lip of a new oil seal.

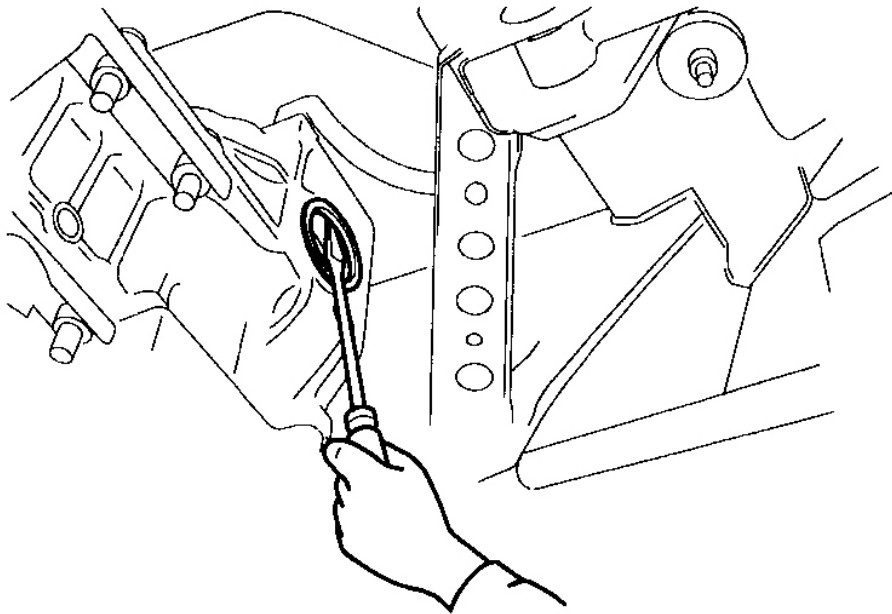

BHJ0314W004

Fig. 6: Removing Oil Seal From Differential Carrier Using Flathead Screwdriver
Courtesy of MAZDA MOTORS CORP.

7. Tap in the new oil seal until it reaches the differential carrier using the SSTs .

NOTE:

- Install the oil seal at a straight angle.

8. After installing a new clip to the rear drive shaft, insert it into the rear differential.

(See **REAR DRIVE SHAFT, REAR KNUCKLE COMPONENT INSTALLATION NOTE** .)

9. Verify that the rear drive shaft is held securely by the clip by pulling the outer ring on the differential side towards the axle.

10. Add differential oil.
11. After adding the oil, perform the oil level inspection. (See **DIFFERENTIAL OIL INSPECTION** .)
12. Install the oil-fill plug with a new washer and tighten.

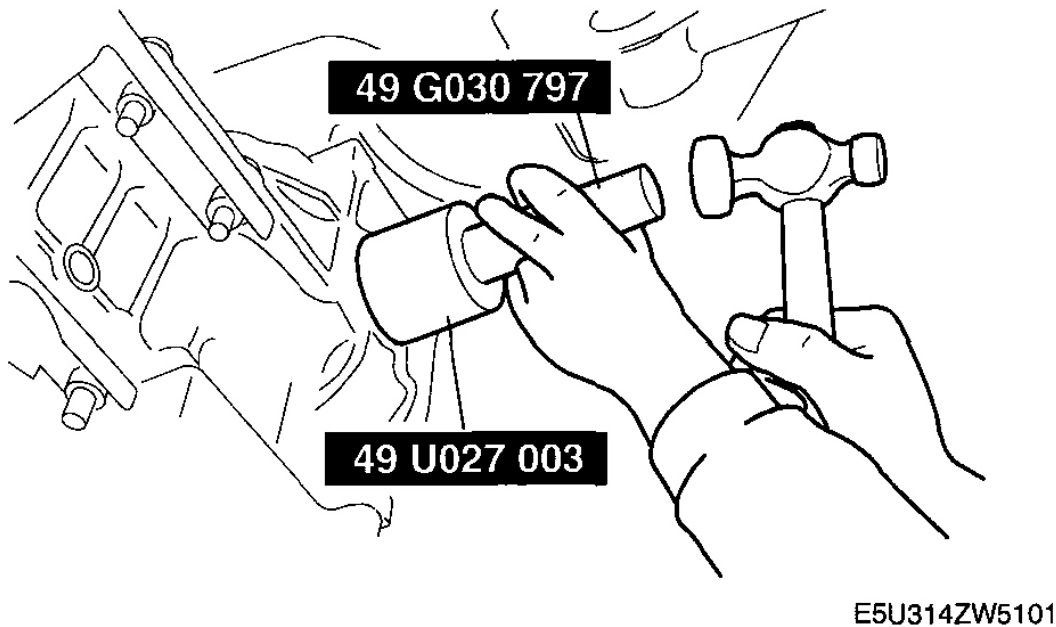

Fig. 7: Tapping In New Oil Seal Using SSTs
Courtesy of MAZDA MOTORS CORP.

Tightening torque

39.2-53.9 N.m {4.00-5.49 kgf.m, 29.0-39.7 ft.lbf}

OIL SEAL (COMPANION FLANGE) REPLACEMENT

1. Remove the rear differential. (See **REAR DIFFERENTIAL REMOVAL/INSTALLATION** .)
2. Replace the oil seal (companion flange) referring to the rear differential disassembly/assembly procedure. (See **REAR DIFFERENTIAL DISASSEMBLY** .) (See **REAR DIFFERENTIAL ASSEMBLY** .)
3. Install the rear differential. (See **REAR DIFFERENTIAL REMOVAL/INSTALLATION** .)

REAR DIFFERENTIAL REMOVAL/INSTALLATION

CAUTION:

- Performing the following procedures without first removing the ABS wheel-speed sensor may possibly cause an open circuit in the wiring

2007 Mazda MX-5 Miata Sport

2007 DRIVELINE/AXLES Differential - MX-5 Miata

harness if it is pulled by mistake. Before performing the following procedures, remove the ABS wheel-speed sensor (axle side) and fix it to an appropriate place where the sensor will not be pulled by mistake while servicing the vehicle.

1. Drain the rear differential oil.
2. Remove the middle pipe. (See **EXHAUST SYSTEM REMOVAL/INSTALLATION [LF]** .)
3. Remove the propeller shaft. (See **PROPELLER SHAFT REMOVAL/INSTALLATION** .)
4. Remove the power plant frame. (See **POWER PLANT FRAME REMOVAL NOTE** .) (See **POWER PLANT FRAME INSTALLATION NOTE** .) (See **POWER PLANT FRAME REMOVAL NOTE** .) (See **POWER PLANT FRAME INSTALLATION NOTE** .) (See **POWER PLANT FRAME REMOVAL NOTE** .) (See **POWER PLANT FRAME INSTALLATION NOTE** .)
5. Remove in the order indicated in **Fig. 8** .
6. Install in the reverse order of removal.
7. Add rear differential oil. (See **DIFFERENTIAL OIL REPLACEMENT** .)

2007 Mazda MX-5 Miata Sport

2007 DRIVELINE/AXLES Differential - MX-5 Miata

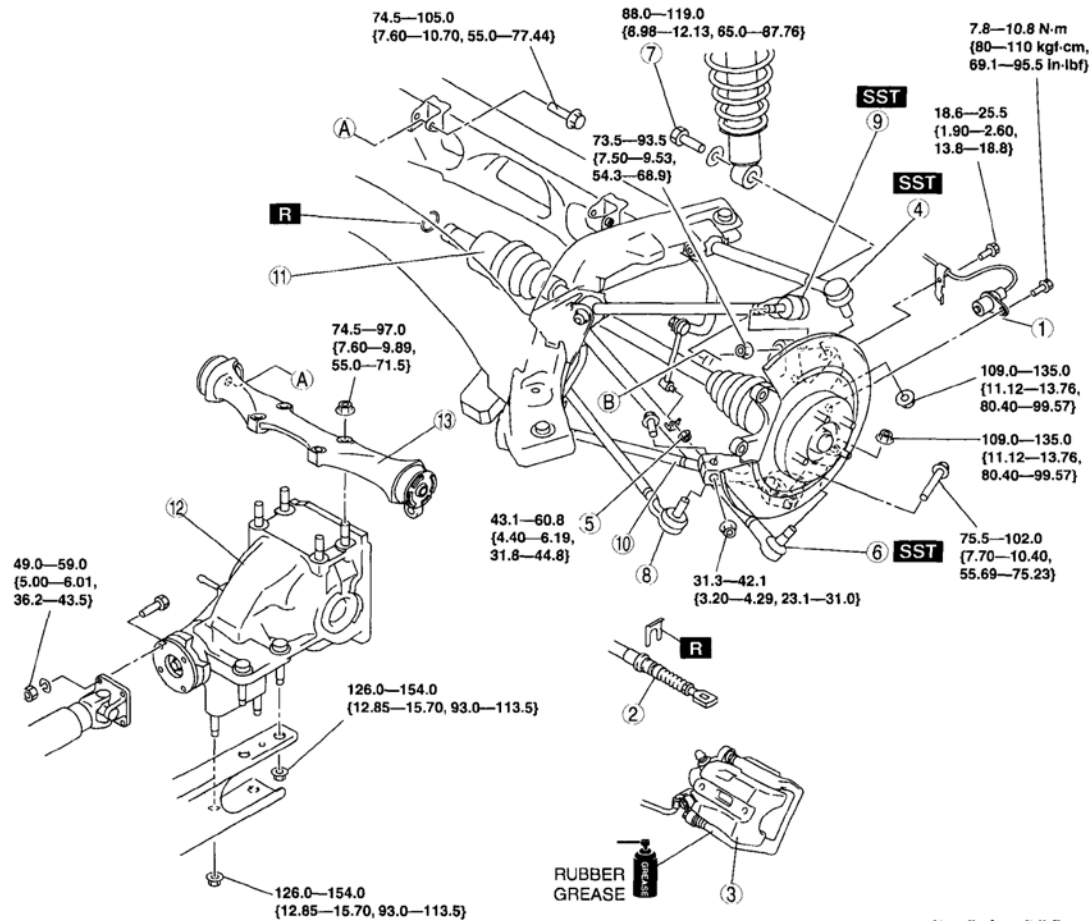

ESU314ZW5004

1	ABS wheel-speed sensor
2	Parking brake cable
3	Brake caliper component
4	Rear lateral link (upper) ball joint
5	Stabilizer control link (lower)
6	Rear lateral link (lower) ball joint
7	Shock absorber bolt (lower)

8	Toe control link ball joint
9	Rear trailing link (upper) ball joint
10	Rear trailing link (lower) bolt (outer side)
11	Rear drive shaft, rear knuckle component
12	Rear differential
13	Differential mount

Fig. 8: Identifying Rear Differential Components (With Torque Specifications)
Courtesy of MAZDA MOTORS CORP.

BRAKE CALIPER COMPONENT REMOVAL NOTE

1. Suspend the brake caliper component using a cable or equivalent.

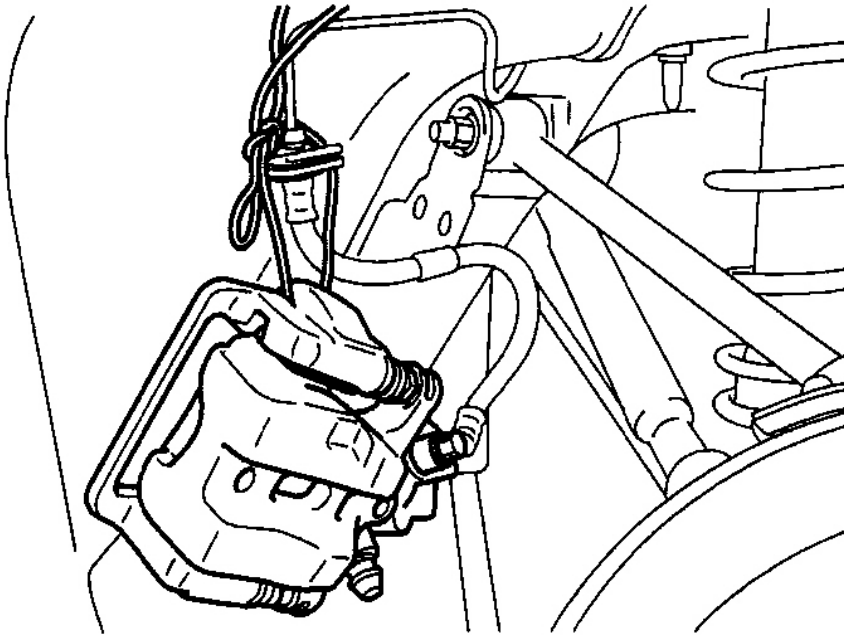

E5U314ZW5001

Fig. 9: Suspending Brake Caliper
Courtesy of MAZDA MOTORS CORP.

2. Temporarily tighten the wheel nut to prevent the disc plate from falling off.

REAR DRIVE SHAFT, REAR KNUCKLE COMPONENT REMOVAL NOTE

1. Insert a tire lever or equivalent between the rear differential and differential side outer ring, and remove the rear drive shaft.

CAUTION:

- The sharp edges of the drive shaft can slice or puncture the oil seal. Be careful not to damage the oil seal when removing the drive shaft from the differential.

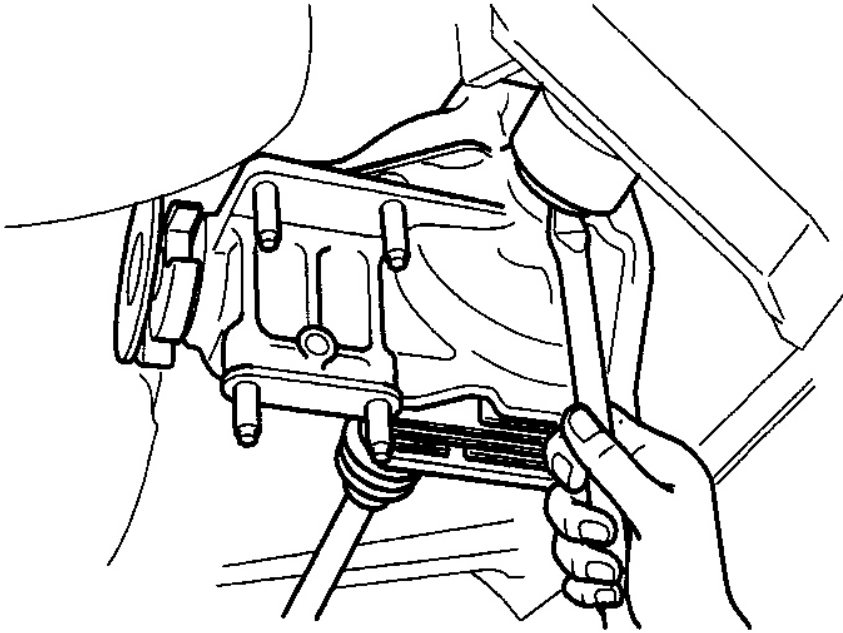

BHJ0314W012

Fig. 10: Removing Rear Drive Shaft & Rear Knuckle Components
Courtesy of MAZDA MOTORS CORP.

2. Pull the rear drive shaft and rear knuckle component to the outer side, and detach the rear drive shaft from the rear differential.
3. To hold the rear drive shaft and rear knuckle component, install the rear lateral link (upper) to the rear knuckle temporarily after disconnecting the rear drive shaft.

REAR DIFFERENTIAL REMOVAL/INSTALLATION NOTE

WARNING:

- **If the rear differential falls off, it can cause serious injuries or death, and damage to the vehicle. When removing/installing the rear differential, verify that it is supported securely with a jack.**

1. Remove or install the rear differential, while supporting it securely with a jack, and moving the jack gradually.

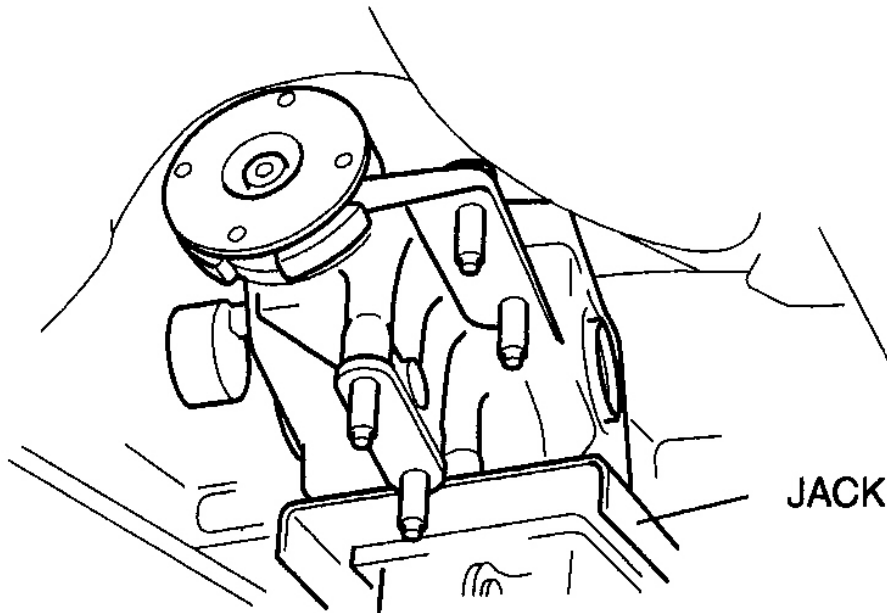

CHU0314W004

Fig. 11: Supporting Differential With Jack
Courtesy of MAZDA MOTORS CORP.

REAR DRIVE SHAFT, REAR KNUCKLE COMPONENT INSTALLATION NOTE

1. Install a new drive shaft clip to the clip groove at the top of the rear drive shaft with the clip opening facing upward and the clip width within the specification.

Standard

31.2 mm {1.23 in}

2. After installing the clip, measure the outer diameter if it exceeds the specification, reinstall a new clip.
3. Apply differential oil to the differential oil seal lip.

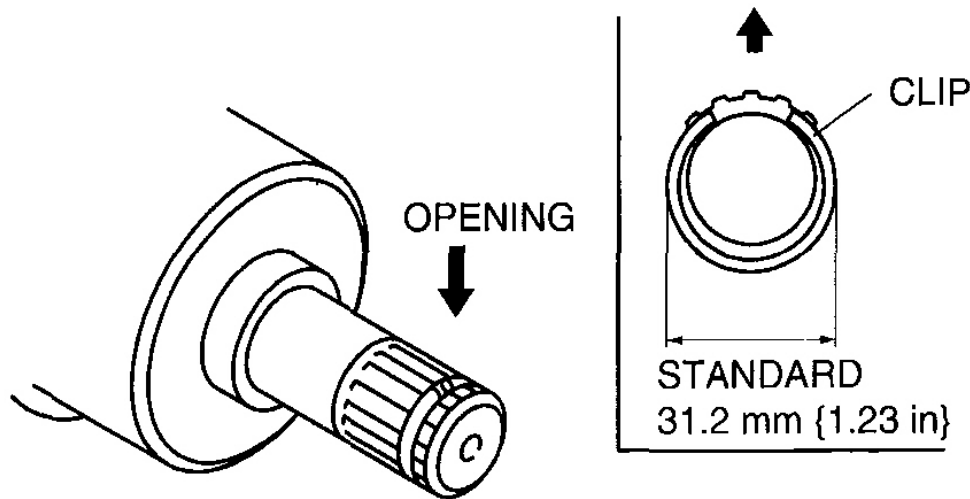

E5U314ZW5006

Fig. 12: Installing New Drive Shaft Clip To Clip Groove At Top Of Rear Drive Shaft
Courtesy of MAZDA MOTORS CORP.

- CAUTION:**
- The sharp edges of the rear drive shaft can slice or puncture the oil seal. Be careful not to damage the oil seal when installing the rear drive shaft from the rear differential.

4. Insert the rear drive shaft into the rear differential with the clip opening facing upward.
5. After installation, verify that the rear drive shaft is securely held by the clip by pulling the outer ring on the differential side towards the axle.

REAR DIFFERENTIAL DISASSEMBLY

- WARNING:**
- The engine stand is equipped with a self-lock mechanism, however, if the rear differential is tilted, the self-lock mechanism could become inoperative. If the rear differential unexpectedly rotates, it could cause injury, therefore do not maintain the rear differential tilted. When turning the rear differential, grasp the rotation handle firmly.

1. Disassemble in the order indicated in **Fig. 13**.

2007 Mazda MX-5 Miata Sport

2007 DRIVELINE/AXLES Differential - MX-5 Miata

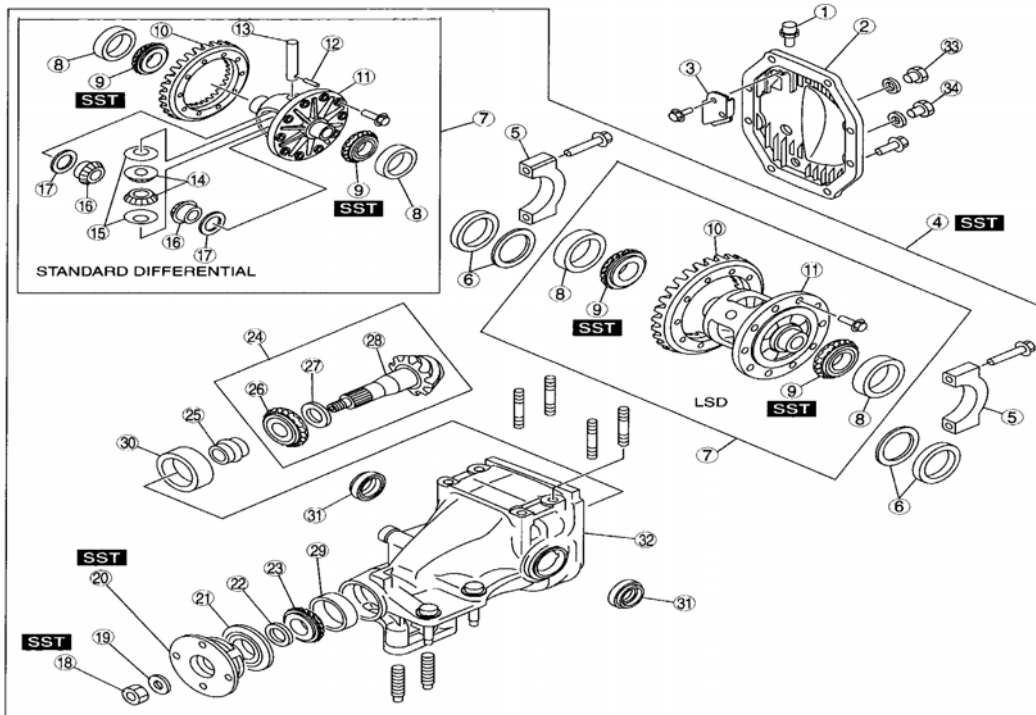

E5U314ZW5002

1	Breather plug
2	Rear cover
3	Baffle plate
4	Differential component
5	Bearing cap
6	Adjustment shim
7	Differential gear case component
8	Side bearing outer race
9	Side bearing
10	Ring gear
11	Gear case
12	Roll pin
13	Pinion shaft

14	Pinion gear
15	Thrust washer
16	Side gear
17	Washer
18	Locknut
19	Washer
20	Companion flange
21	Oil seal (companion flange)
22	Spacer
23	Front bearing
24	Drive pinion component
25	Collapsible spacer
26	Rear bearing
27	Spacer
28	Drive pinion
29	Front bearing outer race
30	Rear bearing outer race
31	Oil seal (side gear)
32	Differential carrier
33	Oil-fill plug
34	Drain plug

Fig. 13: Exploded View Of Rear Differential Components
 Courtesy of MAZDA MOTORS CORP.

DIFFERENTIAL COMPONENT DISASSEMBLY NOTE

1. Install the differential component to the SSTs .

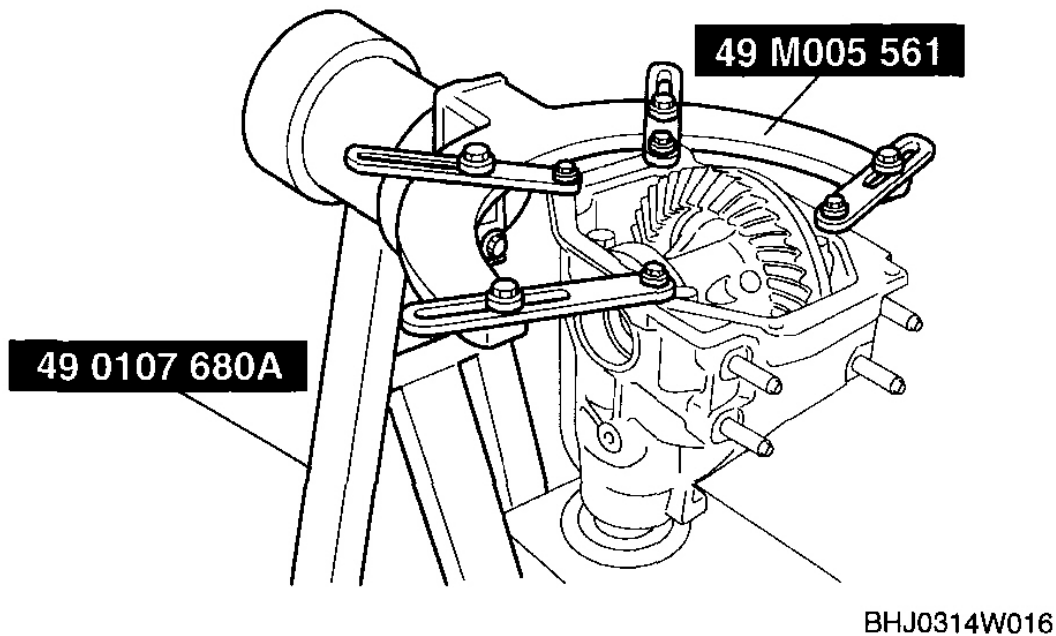
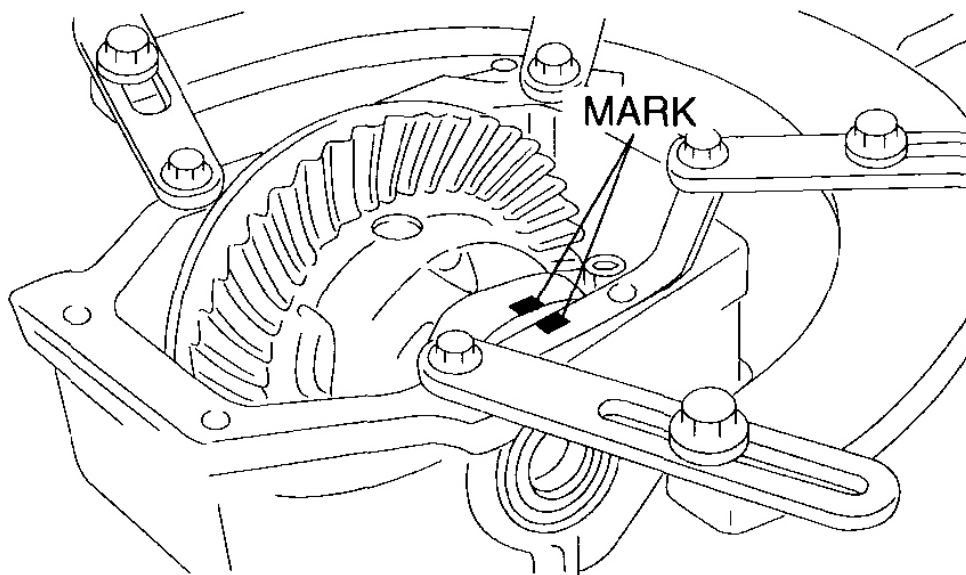

Fig. 14: Installing Differential Component To SSTs
Courtesy of MAZDA MOTORS CORP.

BEARING CAP DISASSEMBLY NOTE

1. Mark the bearing cap and differential carrier for proper installation.



CHU0314W007

Fig. 15: Marking Bearing Cap & Differential Carrier For Installation
Courtesy of MAZDA MOTORS CORP.

ADJUSTMENT SHIM, SIDE BEARING OUTER RACE DISASSEMBLY NOTE

1. Remove the adjustment shim using a flathead screwdriver.

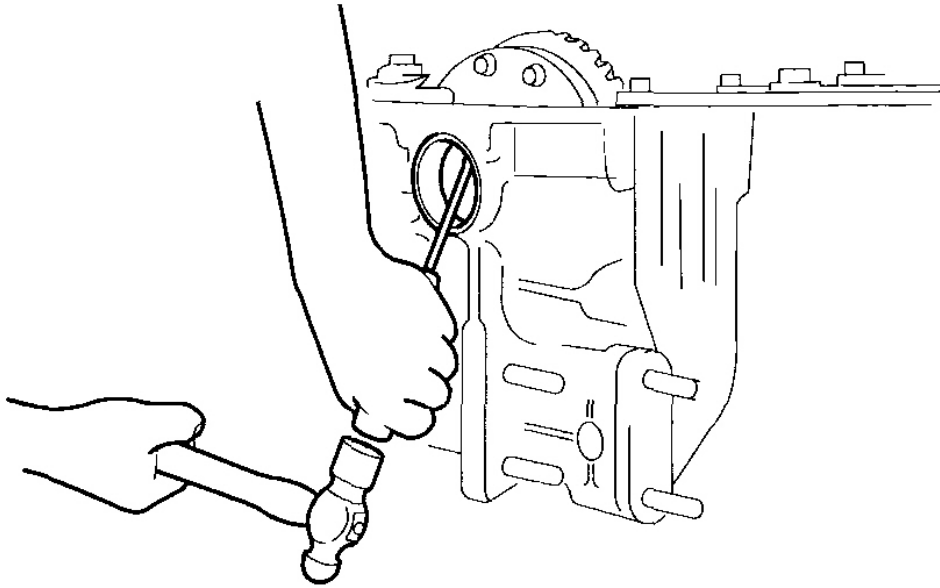

BHJ0314W018

Fig. 16: Removing Adjustment Shim Using Flathead Screwdriver
Courtesy of MAZDA MOTORS CORP.

2. Put left and right identification marks on the removed adjustment shims and side bearing outer races.

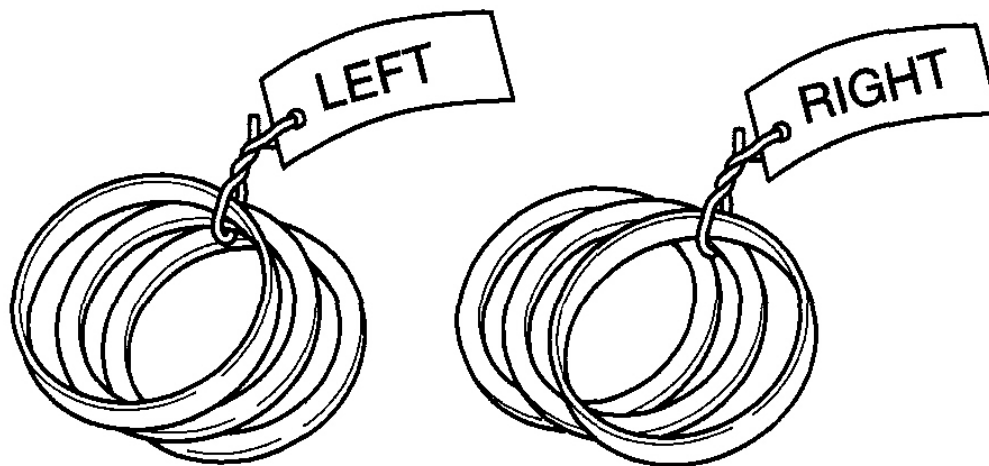

E5U314ZW5005

Fig. 17: Putting Left & Right Identification Marks On Adjustment Shims & Side Bearing Outer Races

Courtesy of MAZDA MOTORS CORP.

SIDE BEARING DISASSEMBLY NOTE

1. Remove the side bearing using the SST .
2. Put left and right identification marks on the removed side bearings.

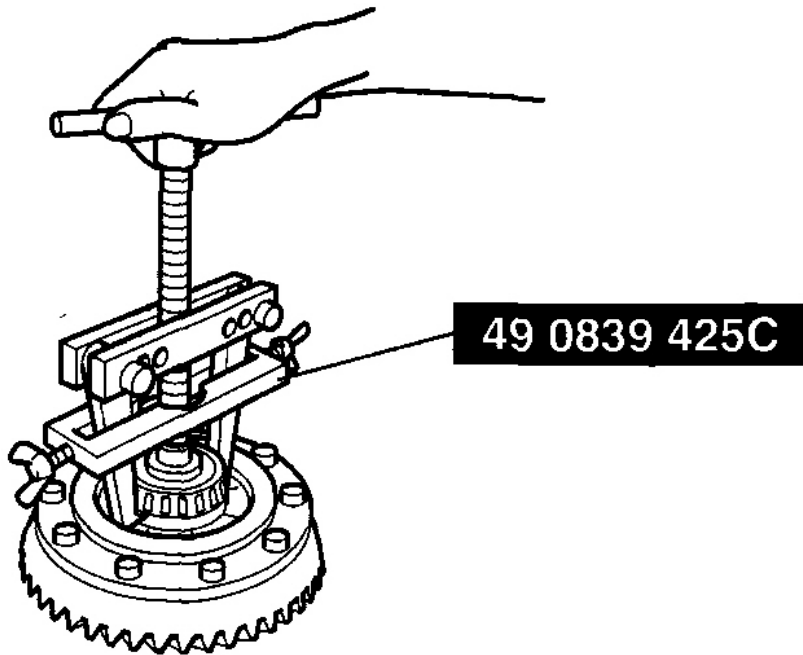

BHJ0314W020

Fig. 18: Removing Side Bearing Using SST
Courtesy of MAZDA MOTORS CORP.

ROLL PIN DISASSEMBLY NOTE

1. Tap the roll pin out from the direction shown in **Fig. 19** using a pin punch.

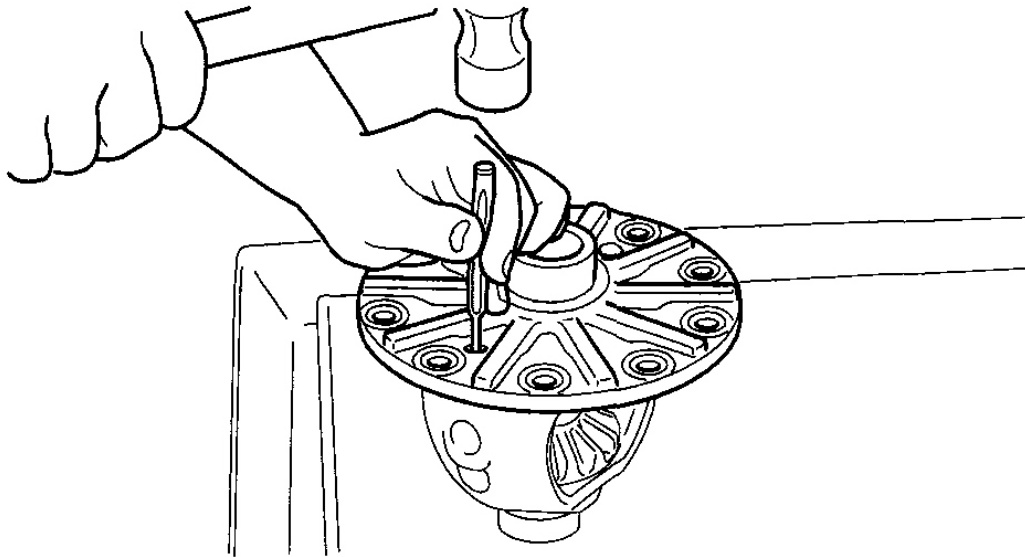

BHJ0314W021

Fig. 19: Tapping Roll Pin Out Using Pin Punch
Courtesy of MAZDA MOTORS CORP.

LOCKNUT DISASSEMBLY NOTE

1. Remove the locknut while fixing the companion flange using the SST .

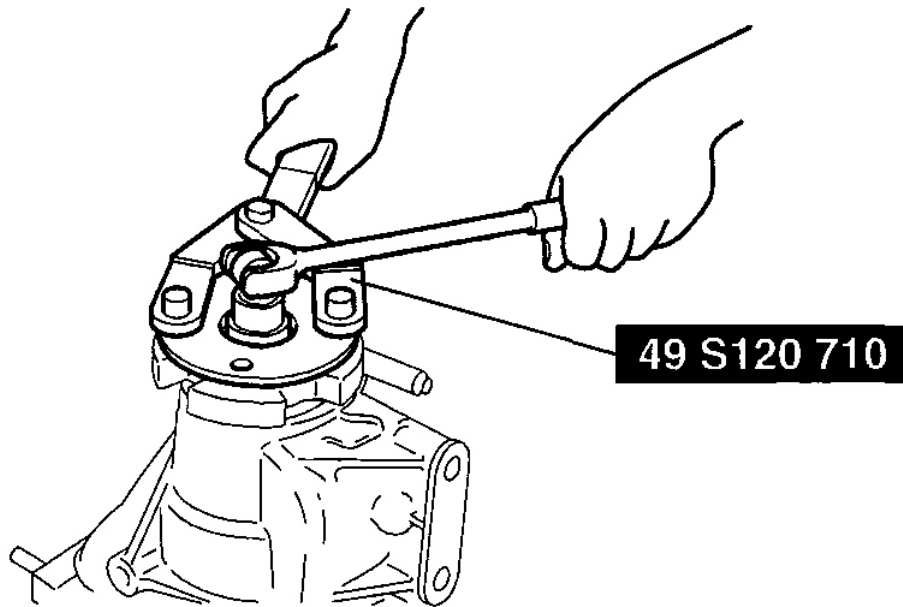

BHJ0314W022

Fig. 20: Removing Locknut While Fixing Companion Flange Using SST
Courtesy of MAZDA MOTORS CORP.

COMPANION FLANGE DISASSEMBLY NOTE

1. Remove the companion flange using the SST .



BHJ0314W023

Fig. 21: Removing Companion Flange Using SST
Courtesy of MAZDA MOTORS CORP.

DRIVE PINION COMPONENT DISASSEMBLY NOTE

1. Install the removed locknut to the drive pinion top to prevent damage to the thread.
2. Remove the drive pinion component by tapping the locknut lightly using a plastic hammer.
3. Remove the locknut installed in Step 1.

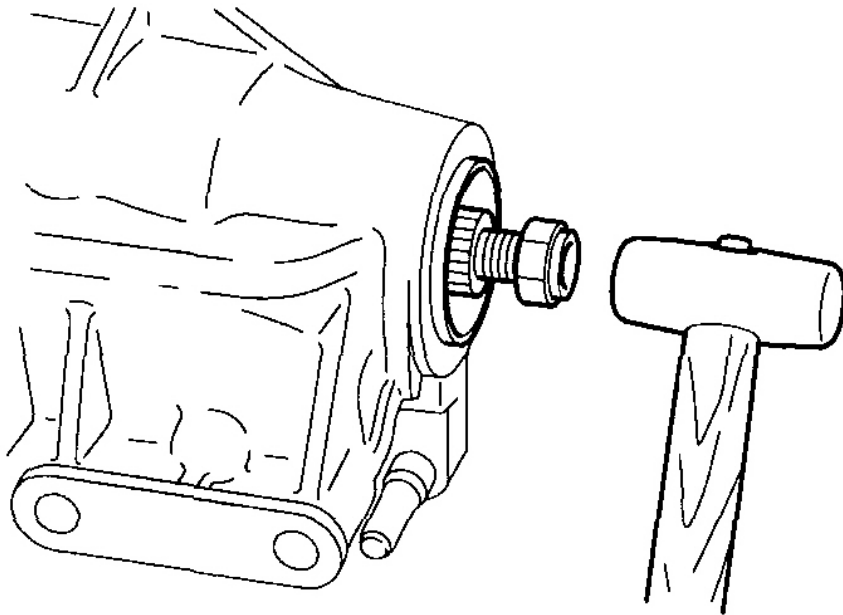

BHJ0314W024

Fig. 22: Removing Drive Pinion Component By Tapping Locknut Using Plastic Hammer
Courtesy of MAZDA MOTORS CORP.

REAR BEARING DISASSEMBLY NOTE

- CAUTION:**
- The drive pinion could be damaged if it falls off. Support the drive pinion with your hand when removing the rear bearing.

1. Remove the rear bearing using the SST and a press.

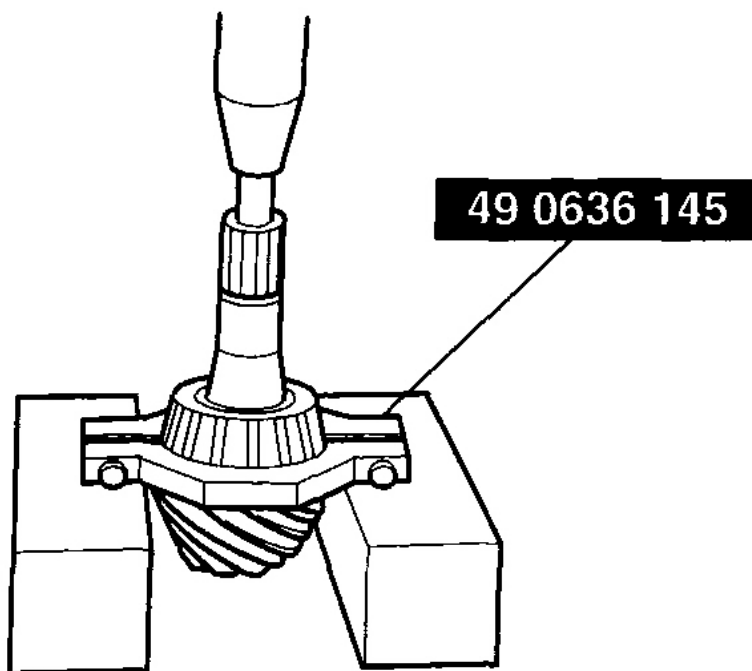

BHJ0314W025

Fig. 23: Removing Rear Bearing Using SST & Press
Courtesy of MAZDA MOTORS CORP.

FRONT BEARING OUTER RACE, REAR BEARING OUTER RACE DISASSEMBLY NOTE

1. Remove the bearing outer race by lightly tapping the edge of the bearing outer race using a flathead screwdriver.

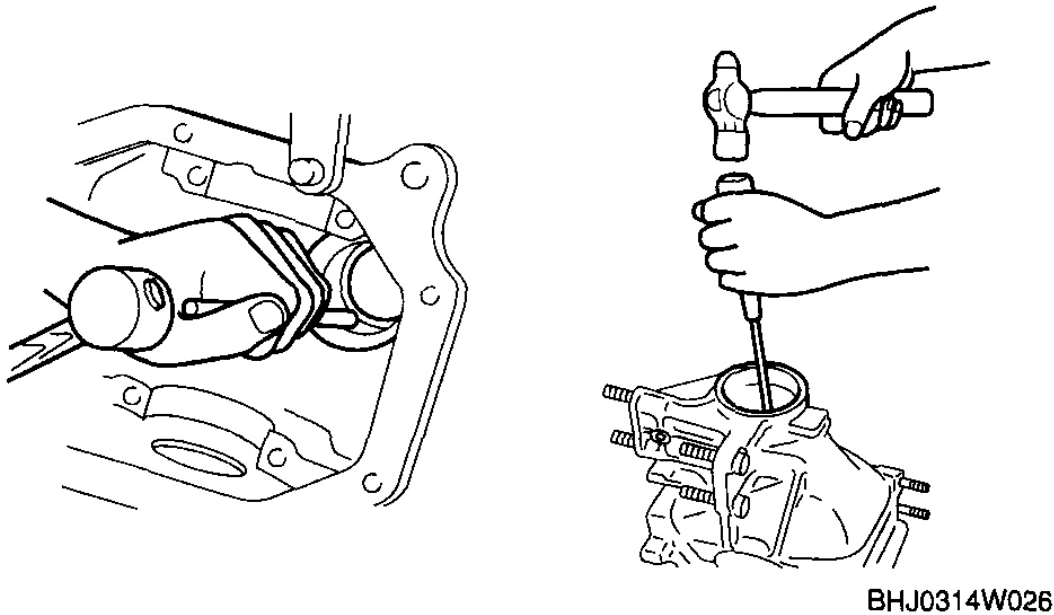

Fig. 24: Removing Bearing Outer Race By Lightly Tapping Edge Of Bearing Outer Race Using Flathead Screwdriver

Courtesy of MAZDA MOTORS CORP.

REAR DIFFERENTIAL ASSEMBLY

WARNING:

- The engine stand is equipped with a self-lock mechanism, however, if the rear differential is tilted, the self-lock mechanism could become inoperative. If the rear differential unexpectedly rotates, it could cause injury, therefore do not maintain the rear differential tilted. When turning the rear differential, grasp the rotation handle firmly.

NOTE:

- Clean away the old silicone sealant before applying the new silicone sealant.
- Install the rear cover within 10 min after applying the silicone sealant.
- Allow the sealant to set at least 30 min or more after installation before filling the differential with differential oil.

1. Assemble in the order indicated in **Fig. 25** .

2007 Mazda MX-5 Miata Sport

2007 DRIVELINE/AXLES Differential - MX-5 Miata

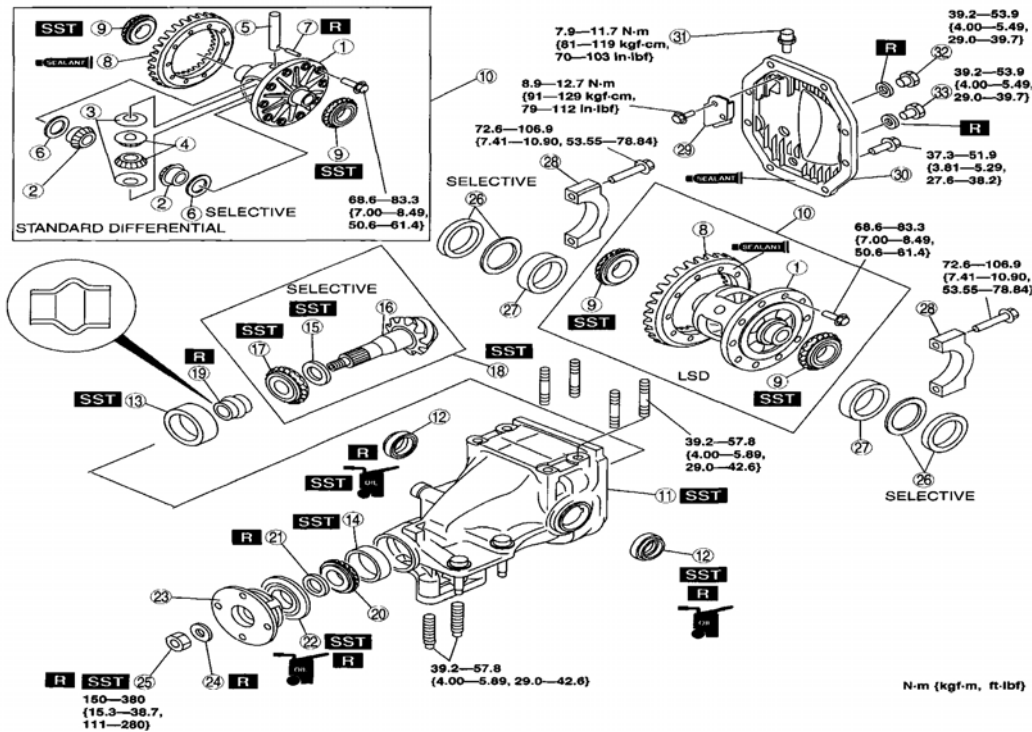

E5U3142W5003

1	Gear case
2	Side gear
3	Thrust washer
4	Pinion gear
5	Pinion shaft
6	Washer
7	Roll pin
8	Ring gear
9	Side bearing
10	Differential gear case component
11	Differential carrier
12	Oil seal (side gear)
13	Rear bearing outer race
14	Front bearing outer race
15	Spacer
16	Drive pinion
17	Rear bearing
18	Drive pinion component

19	Collapsible spacer
20	Front bearing
21	Spacer
22	Oil seal (companion flange)
23	Companion flange
24	Washer
25	Locknut
26	Adjustment shim
27	Side bearing race
28	Bearing cap
29	Baffle plate
30	Rear cover
31	Breather plug
32	Oil-level plug
33	Drain plug

Fig. 25: Identifying Rear Differential Assembly Components (With Torque Specifications)
Courtesy of MAZDA MOTORS CORP.

WASHER ASSEMBLY NOTE

1. Assemble the side gear, thrust washer, pinion gear, and the pinion shaft to the gear case.
2. Install the dial gauge with the measuring probe of the dial gauge attached perpendicularly to the end of

one of the pinion gear teeth.

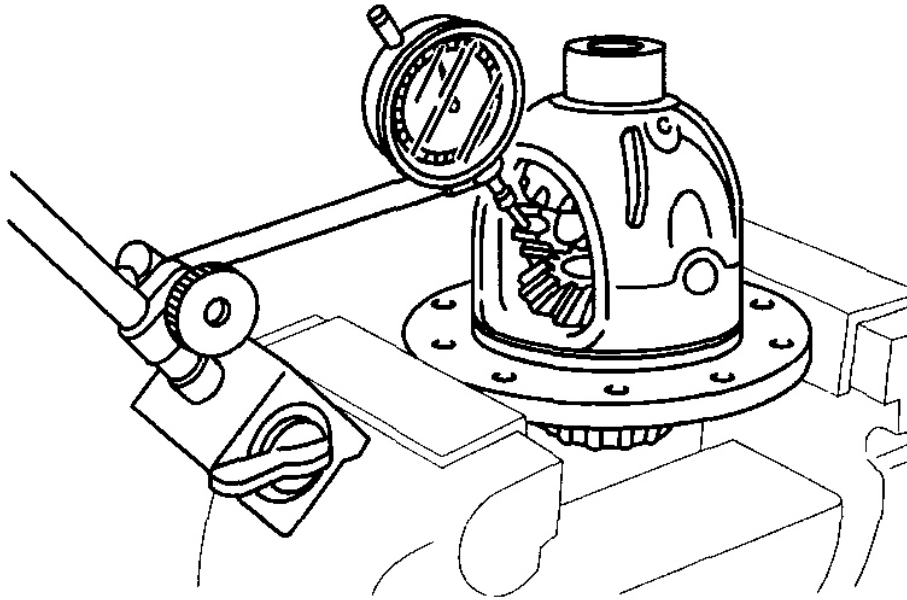

A6A63192021

Fig. 26: Installing Dial Gauge
 Courtesy of MAZDA MOTORS CORP.

3. Fix either one of the side gears.
4. Move the pinion gear and measure the backlash at the pinion gear top.
 - If it is not within the specification, adjust by choosing the proper washer.

Backlash of pinion gear and side gear

0.1 mm {0.004 in} or less

WASHER TABLE

Identification mark	Part name	Thickness (mm {in})
9	MA29 27 252	0.90 {0.0354}
95	MA29 27 253	0.95 {0.0374}
0	MA29 27 254	1.00 {0.0393}
05	MA29 27 256	1.05 {0.0413}
1	MA29 27 257	1.10 {0.0433}

ROLL PIN ASSEMBLY NOTE

1. Align the differential gear case and pinion shaft pin holes.
2. Tap the roll pin in using a pin punch.

RING GEAR ASSEMBLY NOTE

CAUTION:

- The gear case and ring gear could be damaged if the ring gear is installed with old thread-locking compound remaining on the bolt threads. Before installing the ring gear, completely remove the old thread-locking compound from the bolt threads.

1. Apply a small amount of thread-locking compound to each of points A on the back of the ring gear, and bolt thread areas B (around the entire ring).

Application thickness

Back of ring gear points A:

Approx. 0.4 cm^3 {0.4 cc, 0.024 cu in} (1 location approx. 0.04 cm^3 {0.04 cc, 0.0024 cu in})

Ring gear bolt thread points B:

Approx. 0.4 cm^3 {0.4 cc, 0.024 cu in} (1 location approx. 0.04 cm^3 {0.04 cc, 0.0024 cu in})

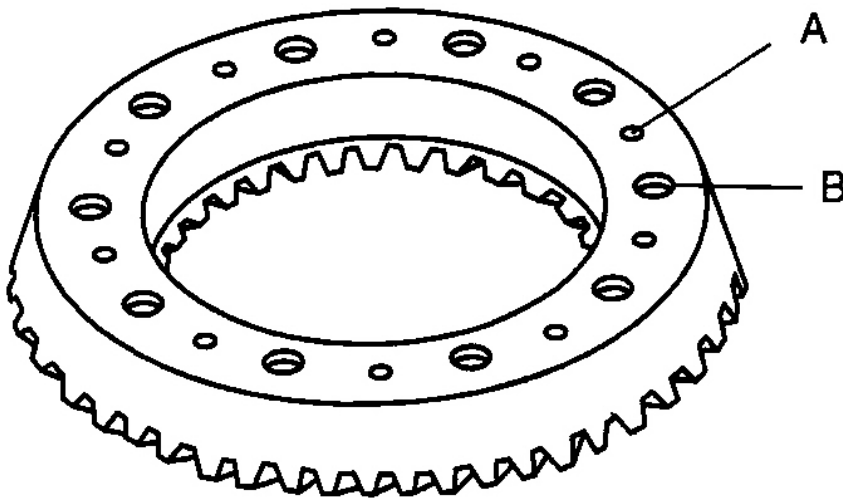

Fig. 27: Identifying Ring Gear Assembly
Courtesy of MAZDA MOTORS CORP.

2. Install the ring gear to the differential gear case and tighten the bolts in a criss-cross pattern.

Tightening torque

68.6-83.3 N.m

{7.00-8.49 kgf.m, 50.6-61.4 ft.lbf}

SIDE BEARING ASSEMBLY NOTE

NOTE:

- When assembling the side bearings, do not mix the left and right side bearings that were identified during disassembly.

1. Press the side bearing in using the SST and a press.

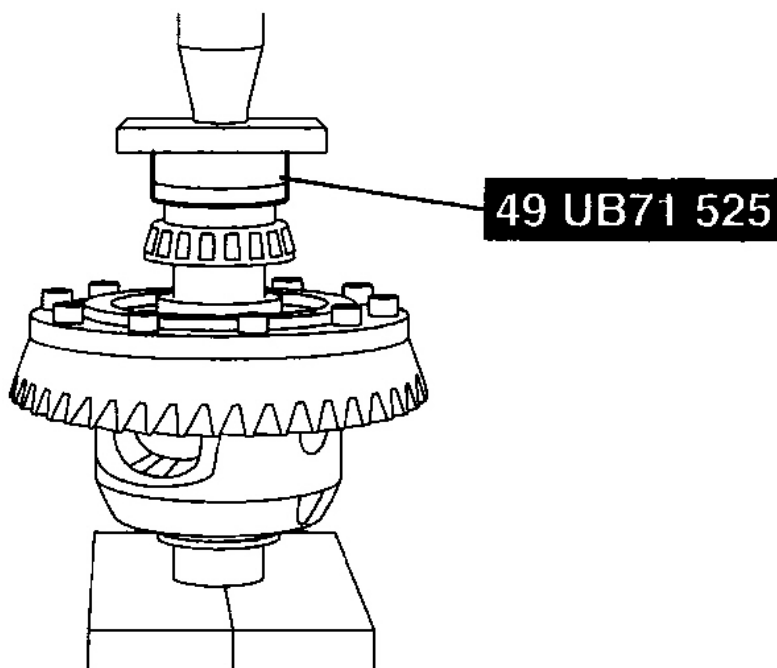

BHJ0314W027

Fig. 28: Pressing Side Bearing In Using SST & Press
Courtesy of MAZDA MOTORS CORP.

OIL SEAL (SIDE GEAR) ASSEMBLY NOTE

1. Apply differential oil to the lip of a new oil seal.
2. Assemble the oil seal using the SSTs .

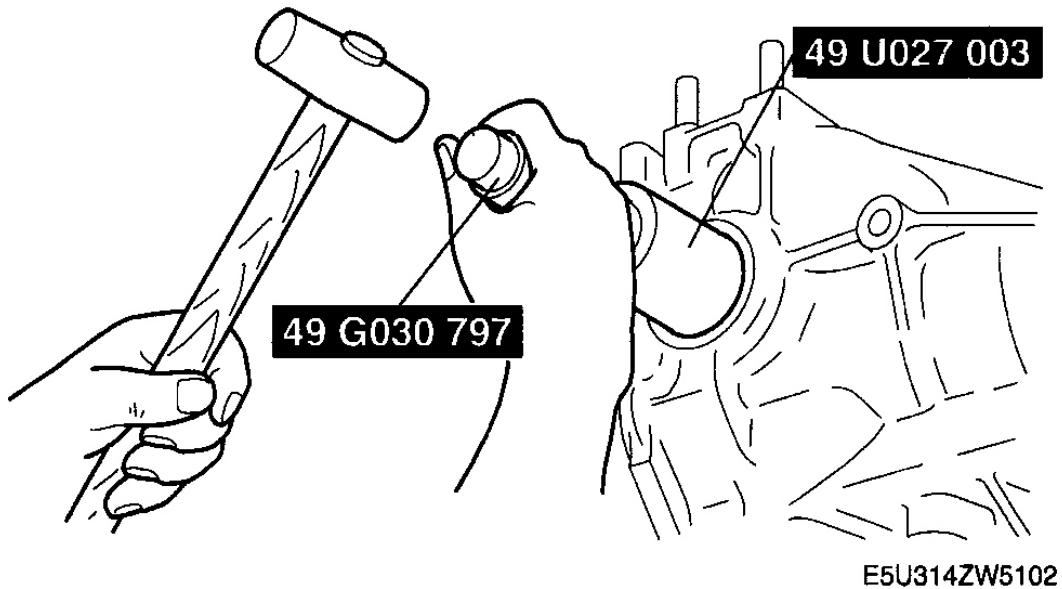
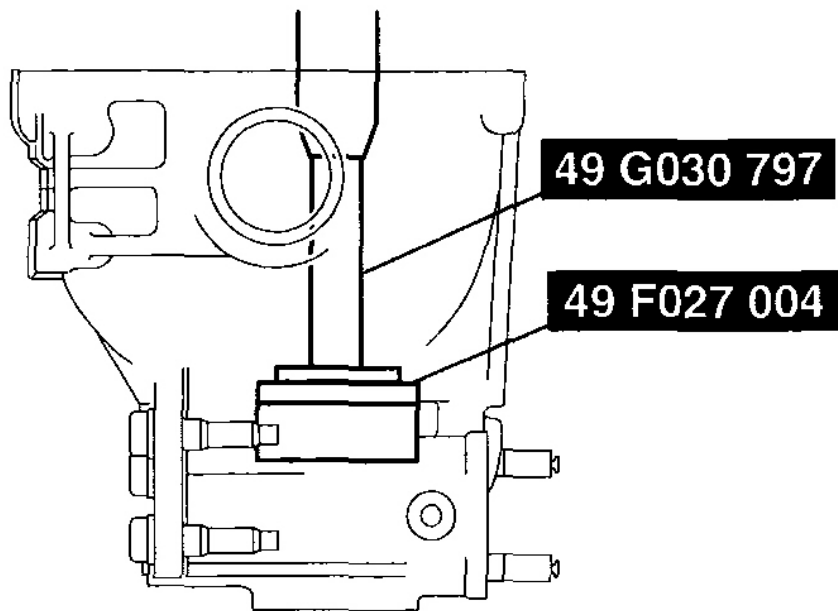

Fig. 29: Assembling Oil Seal Using SSTs
Courtesy of MAZDA MOTORS CORP.

REAR BEARING OUTER RACE ASSEMBLY NOTE

1. Press the rear bearing outer race into the differential carrier using the SST and a press.



E5U314ZW5008

Fig. 30: Pressing Rear Bearing Outer Race Into Differential Carrier Using SST & Press
Courtesy of MAZDA MOTORS CORP.

FRONT BEARING OUTER RACE ASSEMBLY NOTE

1. Press the front bearing outer race into the differential carrier using the **SST** and a press.

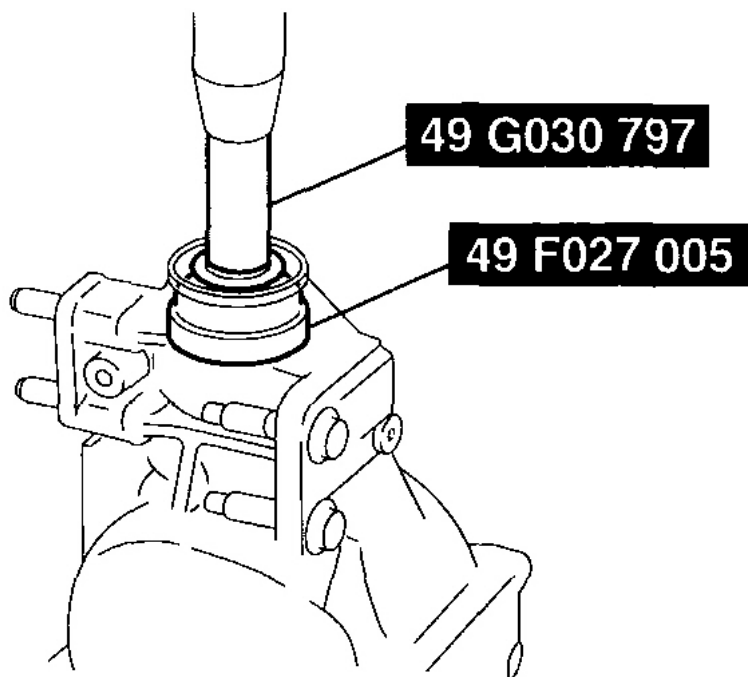

E5U314ZW5009

Fig. 31: Pressing Front Bearing Outer Race Into Differential Carrier Using SST & Press
Courtesy of MAZDA MOTORS CORP.

SPACER ASSEMBLY NOTE

Pinion Height Adjustment

NOTE:

- Use the installed spacer when adjusting.
- Install the spacer with the chamfer on the SST side.

1. Assemble the spacer, bearing inner race (rear side), and the SST (O-ring) to the SST (49 8531 565) as shown in **Fig. 32**.

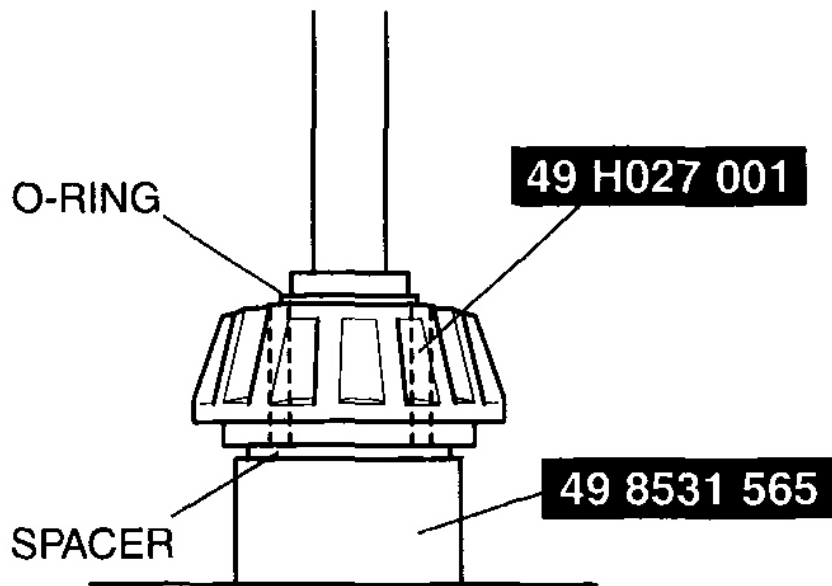

E5U314ZW5100

Fig. 32: Assembling Spacer, Bearing Inner Race (Rear Side) & SST (O-Ring) To SST (49 8531 565)
Courtesy of MAZDA MOTORS CORP.

2. Insert the set assembled in Step 1 from the rear side of the differential carrier.
3. Assemble the **SST** (49 8531 567) front bearing, companion flange, and a washer from the front side of the differential carrier.

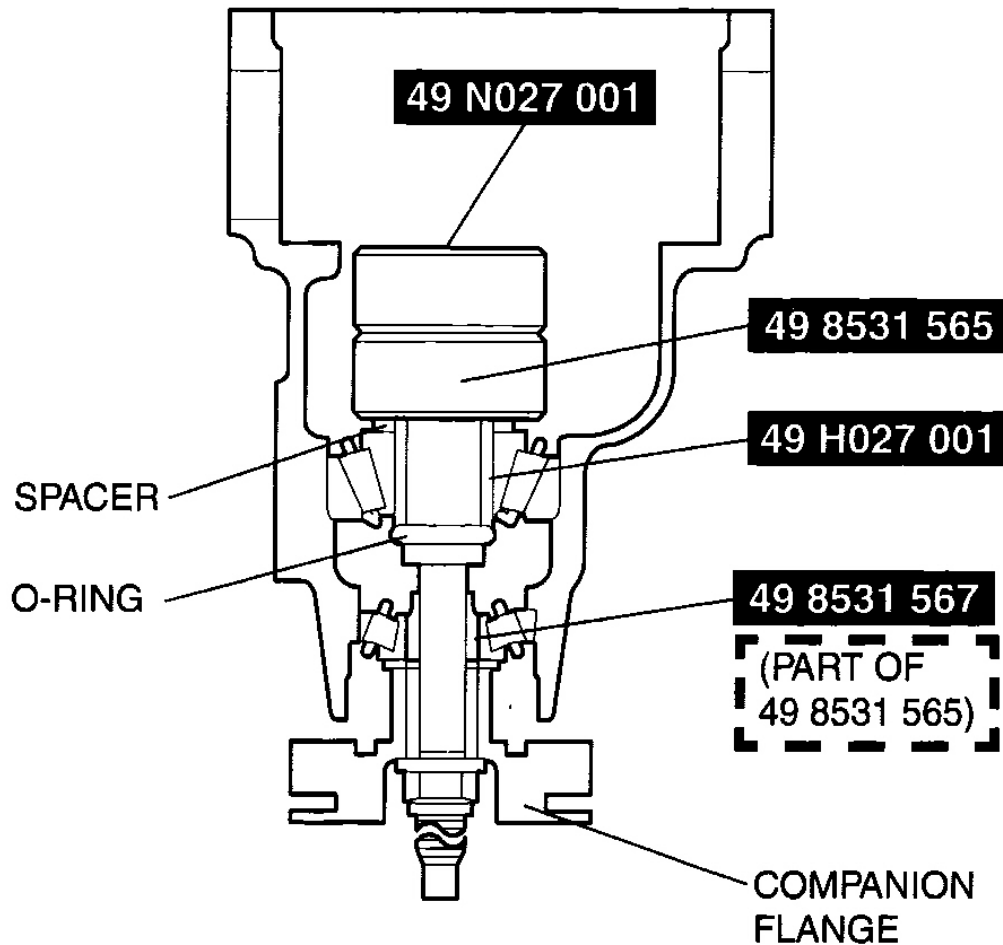

E5U314ZSI001

Fig. 33: Inserting Assembled Set In From Rear Side Of Differential Carrier
Courtesy of MAZDA MOTORS CORP.

4. Tighten the locknut to the extent that the SST (49 8531 565) can be turned by hand.
5. Place the SST (49 N027 001) on top of the SST (49 8531 565).
6. Place the SST on the surface plate and set the dial gauge to zero.

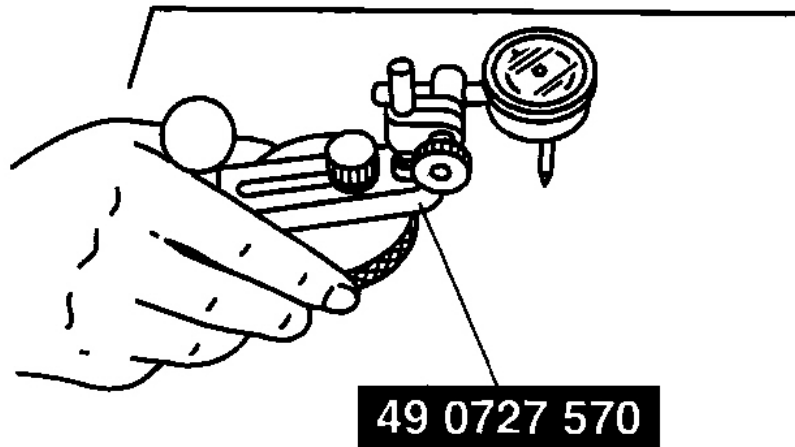

A6A63192026

Fig. 34: Placing SST On Surface Plate & Setting Dial Gauge To Zero
Courtesy of MAZDA MOTORS CORP.

7. Set the SSTs as shown in **Fig. 35** .
8. Place the measuring probe of the dial gauge at the point where the side bearing is installed in the differential carrier and measure at the lowest position. Measure the left and right sides.

2007 Mazda MX-5 Miata Sport

2007 DRIVELINE/AXLES Differential - MX-5 Miata

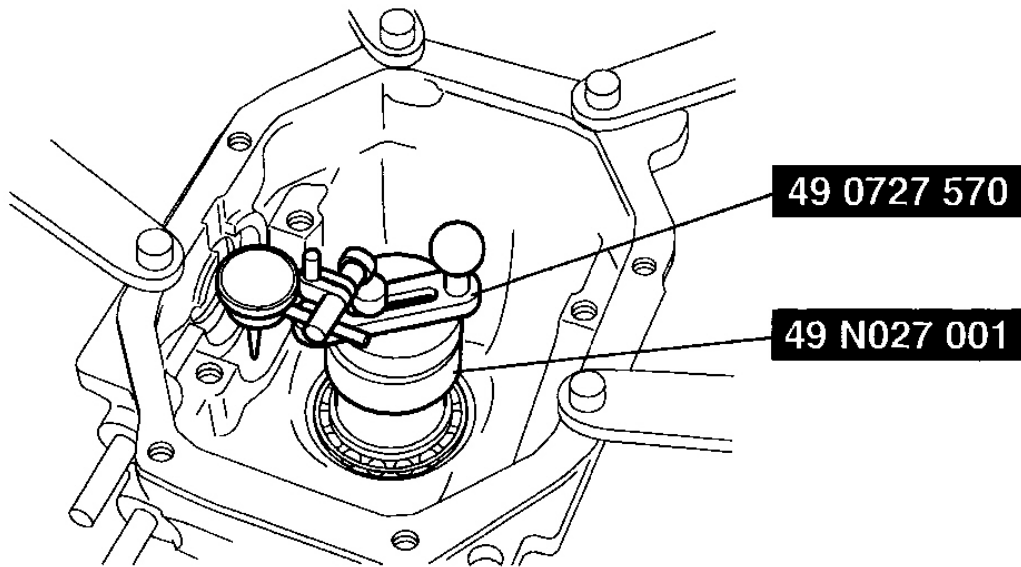

E5U314ZW5011

Fig. 35: Placing Measuring Probe Of Dial Gauge Where Side Bearing Is Installed In Differential Carrier
Courtesy of MAZDA MOTORS CORP.

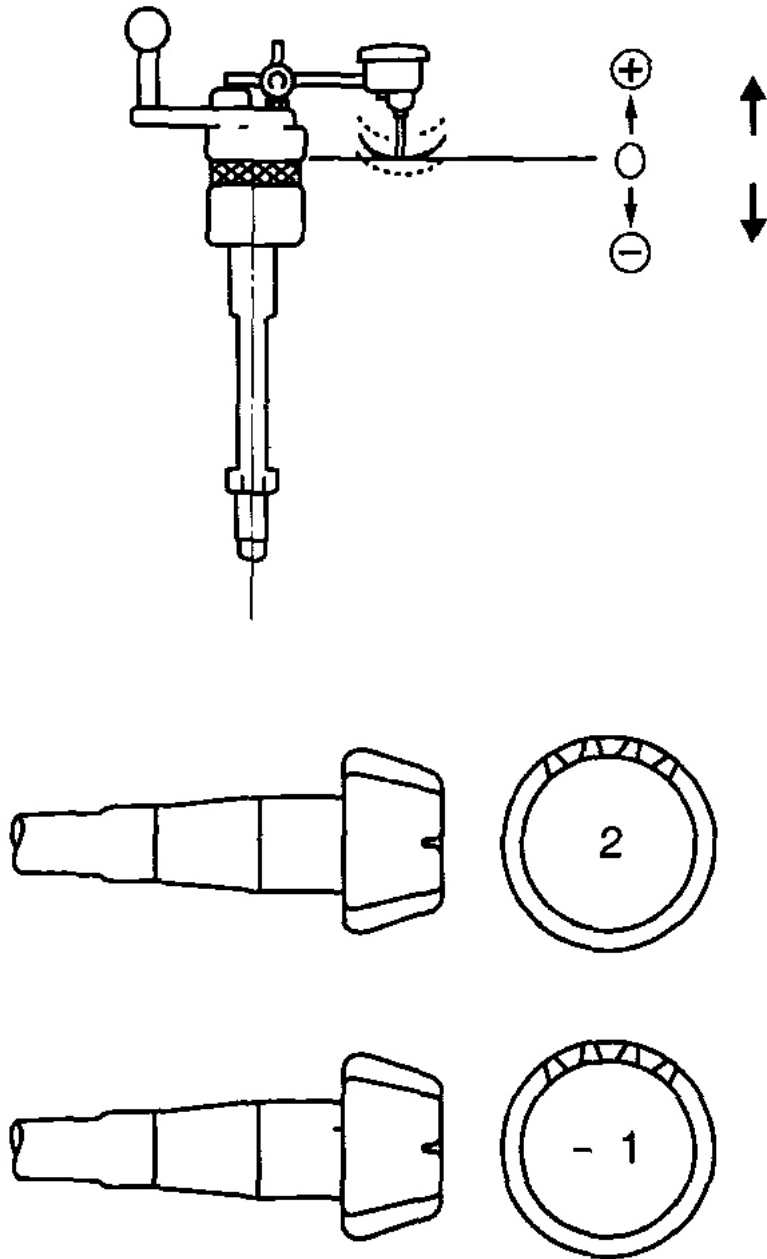

A6A63192028

Fig. 36: Measuring Pinion Height Adjustment Value
Courtesy of MAZDA MOTORS CORP.

2007 Mazda MX-5 Miata Sport

2007 DRIVELINE/AXLES Differential - MX-5 Miata

9. Add the two (left and right) values obtained by the measurements taken in Step 8 and then divide the total by 2 . From this sum, subtract the sum of the number inscribed on the end of the drive pinion divided by 100 . (If there is no figure inscribed, use 0.) This is the pinion height adjustment value.

Differential pinion height

0.038 mm {0.0015 in} or less

NOTE:

- When the values obtained by the measurements taken in Step 8, 9 are 0.06 mm {0.0024 in}, 0.04 mm {0.0016 in} and the tip surface of the drive pinion value is 2, the formula is $((0.06+0.04)/2)-(2/100)=0.03$. Therefore, assemble a spacer 0.03 mm {0.0012} thicker than the currently assembled one. The thickness settings are in increments of 0.015 mm {0.0006}, so choose one closest in thickness and install.

SPACER TABLE

Identification mark	Thickness (mm {in})	Identification mark	Thickness (mm {in})
08	3.080 {0.1213}	29	3.290 {0.1295}
09	3.095 {0.1220}	30	3.305 {0.1301}
11	3.110 {0.1224}	32	3.320 {0.1307}
12	3.125 {0.1230}	33	3.335 {0.1313}
14	3.140 {0.1234}	35	3.350 {0.1319}
15	3.155 {0.1242}	36	3.365 {0.1325}
17	3.170 {0.1248}	38	3.380 {0.1331}
18	3.185 {0.1254}	39	3.395 {0.1337}
20	3.200 {0.1260}	41	3.410 {0.1343}
21	3.215 {0.1266}	42	3.425 {0.1348}
23	3.230 {0.1271}	44	3.440 {0.1354}
24	3.245 {0.1278}	45	3.455 {0.1360}
26	3.260 {0.1283}	47	3.470 {0.1366}
27	3.275 {0.1289}	-	-

REAR BEARING ASSEMBLY NOTE

NOTE:

- Install the spacer with the chamfer on the gear side.

1. Assemble the spacer selected in the pinion height adjustment to the drive pinion.
2. Press the drive pinion into the rear bearing using the SSTs and a press.

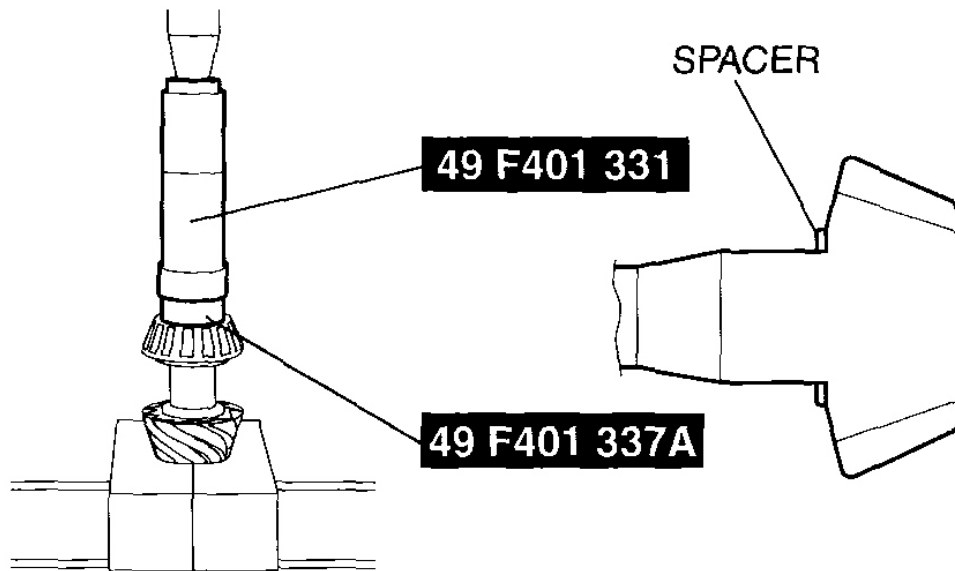

E5U314ZW5012

Fig. 37: Pressing Drive Pinion Into Rear Bearing Using SSTs & Press
Courtesy of MAZDA MOTORS CORP.

DRIVE PINION COMPONENT ASSEMBLY NOTE

Drive Pinion Preload Adjustment

NOTE: • Perform preload adjustment with the oil seal uninstalled.

1. Assemble the following parts to the drive pinion.
 - New collapsible spacer
 - Front bearing
 - New spacer
 - Companion flange
 - New washer
 - New locknut
2. Turn the serrated part of the drive pinion by hand to seat the bearing.
3. Tighten the locknut temporarily tightened in Step 1 from the lower limit of the specified tightening torque using the SST, and obtain the specified preload. Record the tightening torque at this time.

Tightening torque

150-380 N.m {15.3-38.7 kgf.m, 111-280 ft.lbf}

Drive pinion preload

1.3-1.8 N.m {14-18 kgf.cm, 12-15 in.lbf}

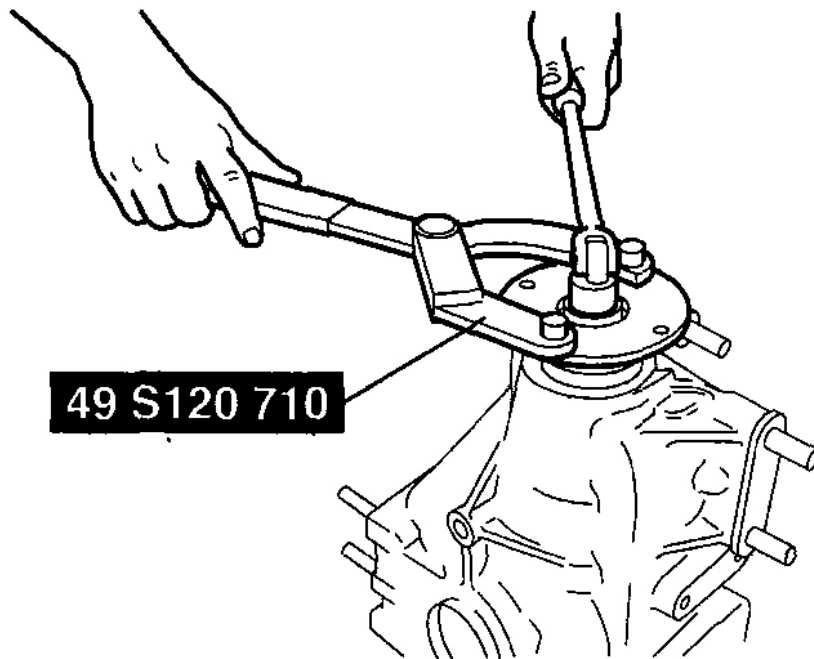

BHJ0314W036

Fig. 38: Tighten Locknut Using SST
Courtesy of MAZDA MOTORS CORP.

- If the specified preload cannot be obtained within the specified tightening torque, replace with a new collapsible spacer and adjust again.
4. Remove the locknut, washer, and companion flange.

OIL SEAL (COMPANION FLANGE) ASSEMBLY NOTE

1. Apply differential oil to the lip of a new oil seal.
2. Assemble the oil seal using the SST .

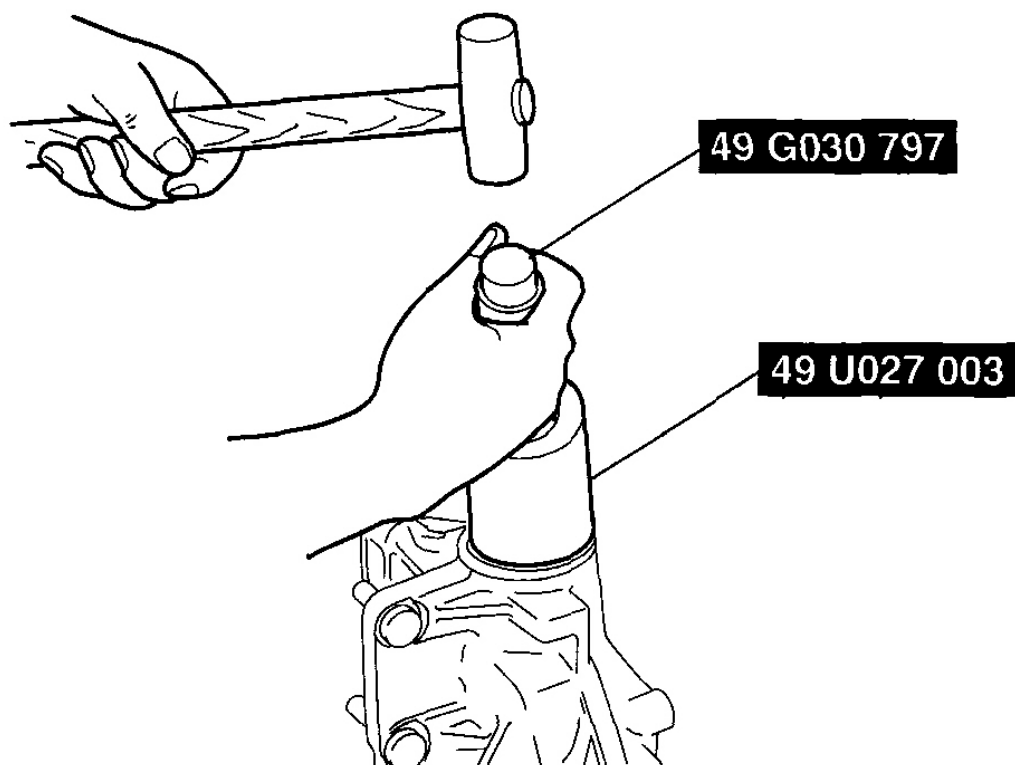

E5U314ZW5013

Fig. 39: Assembling Oil Seal Using SST
Courtesy of MAZDA MOTORS CORP.

LOCKNUT ASSEMBLY NOTE

1. Tighten a new locknut with the torque recorded at the drive pinion preload adjustment using the SST .

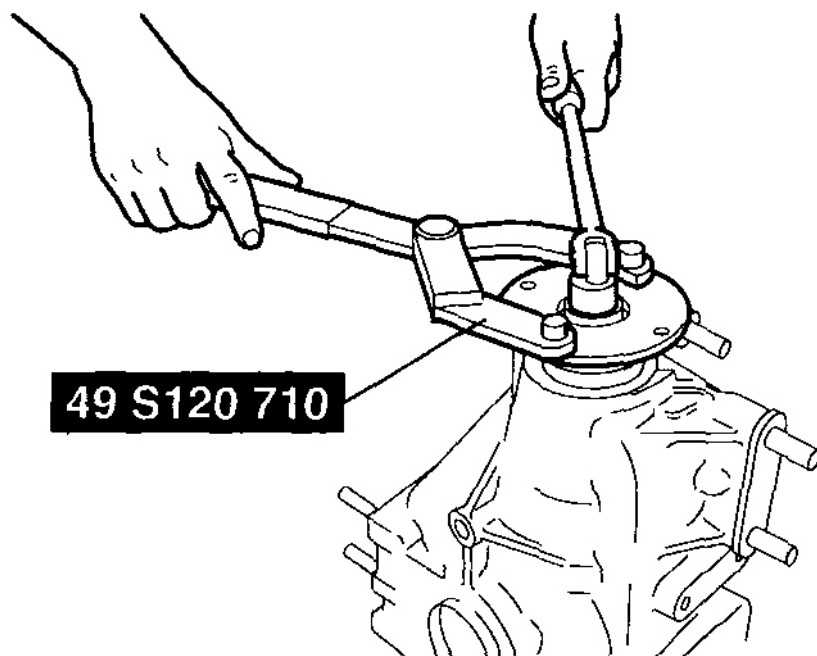

BHJ0314W036

Fig. 40: Tightening Locknut Using SST
Courtesy of MAZDA MOTORS CORP.

2. Verify that the drive pinion preload is within the specification.
 - If not within the specification, perform the preload adjustment again.

Drive pinion preload

1.3-1.8 N.m {14-18 kgf.cm, 12-15 in.lbf}

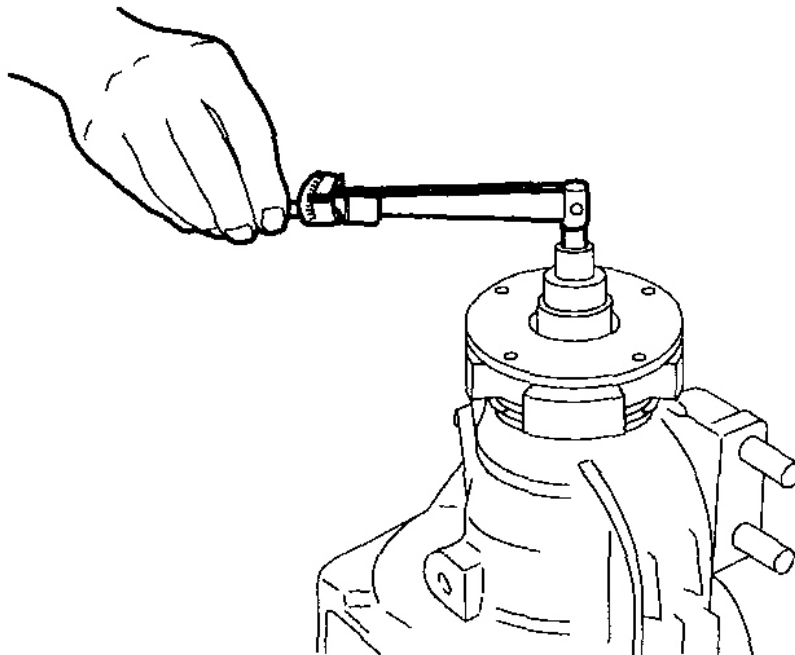

BHJ0314W037

Fig. 41: Measuring Drive Pinion Preload
Courtesy of MAZDA MOTORS CORP.

ADJUSTMENT SHIM ASSEMBLY NOTE

Ring Gear Backlash Adjustment

1. Stack the side bearing race and differential gear case component on the surface plate as shown in **Fig. 42** and measure the height using a caliper and a ruler. This is value A.

Standard Height A

151.4-152.6 mm {5.961-6.007 in}

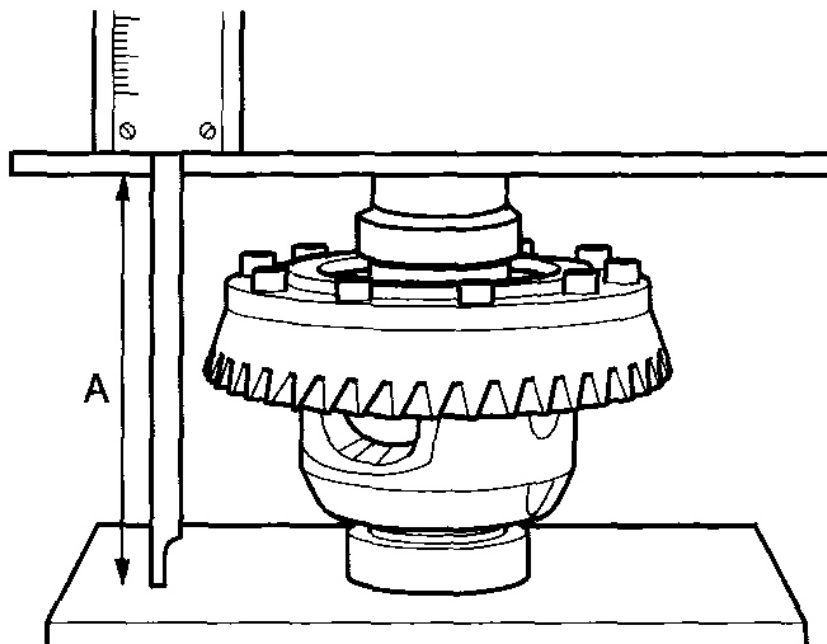

BHJ0314W039

Fig. 42: Measuring Height Using Caliper & Ruler
Courtesy of MAZDA MOTORS CORP.

2. Measure the width of the section of the differential gear case component installed in the differential carrier. This is value B.

Standard width B

171 mm {6.73 in}

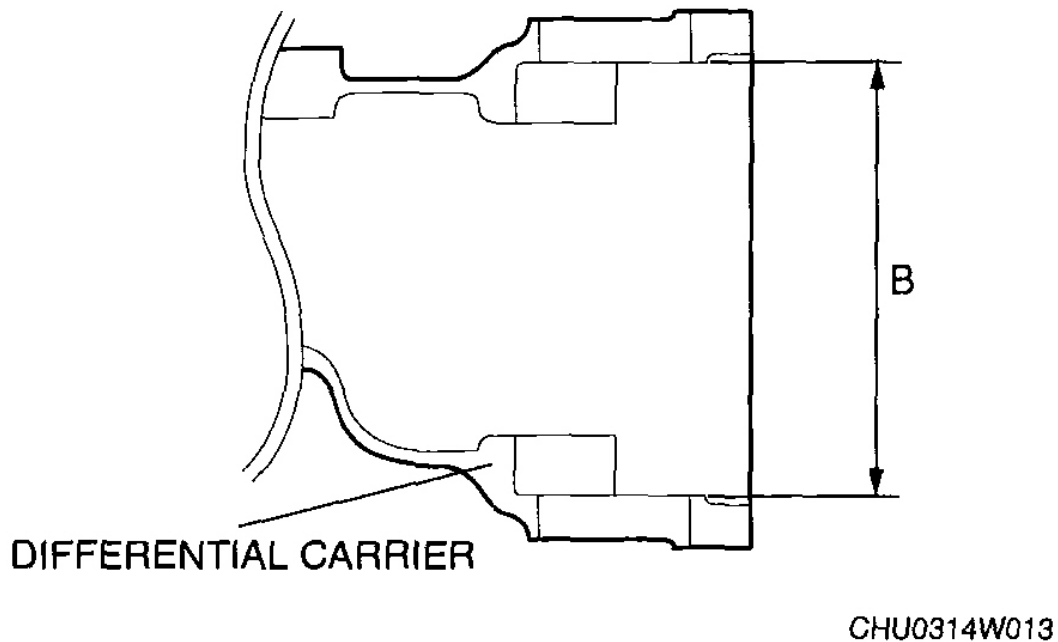

Fig. 43: Measuring Width Of Differential Gear Case Component In Differential Carrier
 Courtesy of MAZDA MOTORS CORP.

1. The combined thickness of the left and right adjustment shims is obtained by the following formula.

Shim thickness (mm {in}) = B - A + (0.01 - 0.03 {0.0004 - 0.0118 in})

2. If the combined thickness of the previously assembled adjustment shims is equal to the calculated thickness, use the shims as they are.
3. If the combined thickness of the previously assembled adjustment shims is not equal to the calculated thickness, or if the adjustment shims have to be replaced, select two appropriate adjustment shims from the table below.

ADJUSTMENT SHIM TABLE

Identification mark	Thickness (mm {in})	Identification mark	Thickness (mm {in})
550	5.50 {0.217}	605	6.05 {0.238}
560	5.60 {0.220}	610	6.10 {0.240}
565	5.65 {0.222}	615	6.15 {0.242}
570	5.70 {0.224}	620	6.20 {0.244}
575	5.75 {0.226}	625	6.25 {0.246}
580	5.80 {0.228}	630	6.30 {0.248}
585	5.85 {0.230}	635	6.35 {0.250}

2007 Mazda MX-5 Miata Sport

2007 DRIVELINE/AXLES Differential - MX-5 Miata

590	5.90 {0.232}	640	6.40 {0.252}
595	5.95 {0.234}	650	6.50 {0.256}
600	6.00 {0.236}	-	-

NOTE:

- If the adjustment shims are to be reused, assemble the left and right shims that were identified during disassembly.
- When assembling the side bearing races, do not mix the left and right side bearings that were identified during disassembly.

4. Assemble the differential gear case component and the side bearing race to the differential carrier.
5. Tap the selected adjustment shim between the differential carrier and the side bearing race with a plastic hammer as shown in **Fig. 44**.

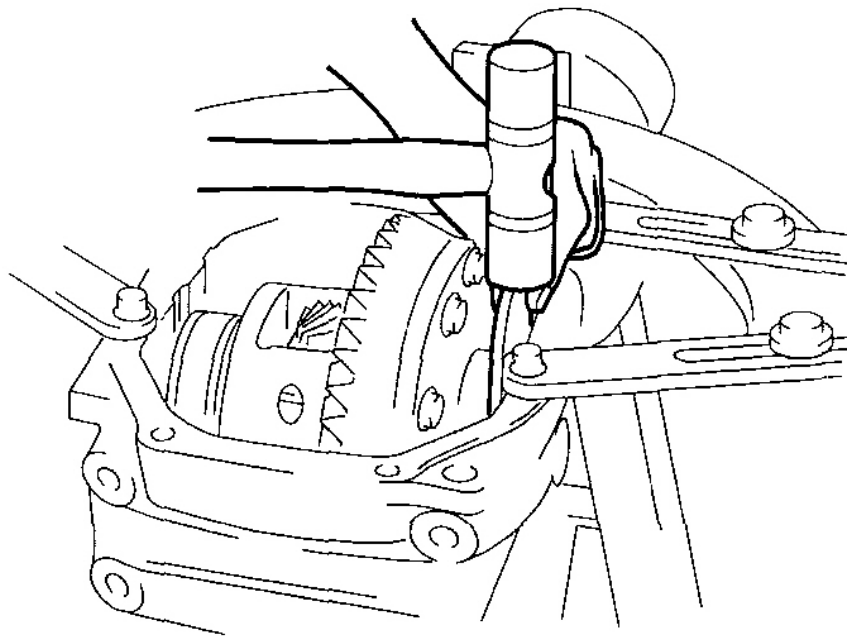

BHJ0314W041

Fig. 44: Tapping Selected Adjustment Shim Between Differential Carrier & Side Bearing Race With Plastic Hammer

Courtesy of MAZDA MOTORS CORP.

6. Align the bearing cap alignment marks, assemble the bearing cap, and then temporarily tighten the bolts.
7. Install the dial gauge with the measuring probe of the dial gauge attached perpendicularly to the end of one of the ring gear teeth.

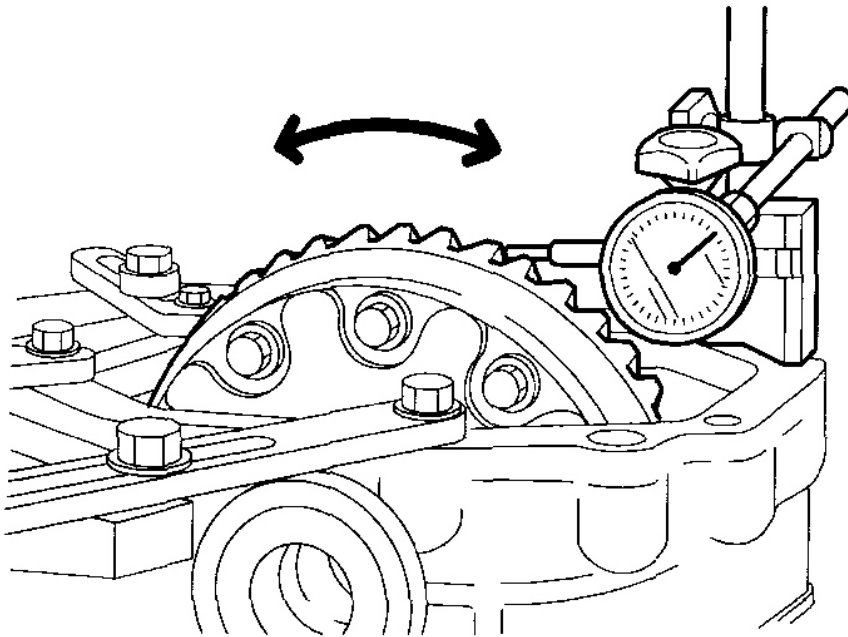

BHE0314W003

Fig. 45: Measuring Probe Of Dial Gauge Attached To End Of One Of Ring Gear Teeth
Courtesy of MAZDA MOTORS CORP.

8. Secure the drive pinion and measure the backlash of the ring gear.

Backlash of drive pinion and ring gear

Standard: 0.09-0.11 mm {0.0035-0.0043 in}

Minimum value: 0.05 mm {0.0020 in} or more

Variance: 0.07 mm {0.0028 in} or less

NOTE:

- Measure the backlash at 4 locations around the ring gear. Make sure all of the 4 locations are within specification, and the minimum value for the 4 locations is 0.05 mm {0.0020 in} or more and the variance is 0.07 mm {0.0028 in} or less

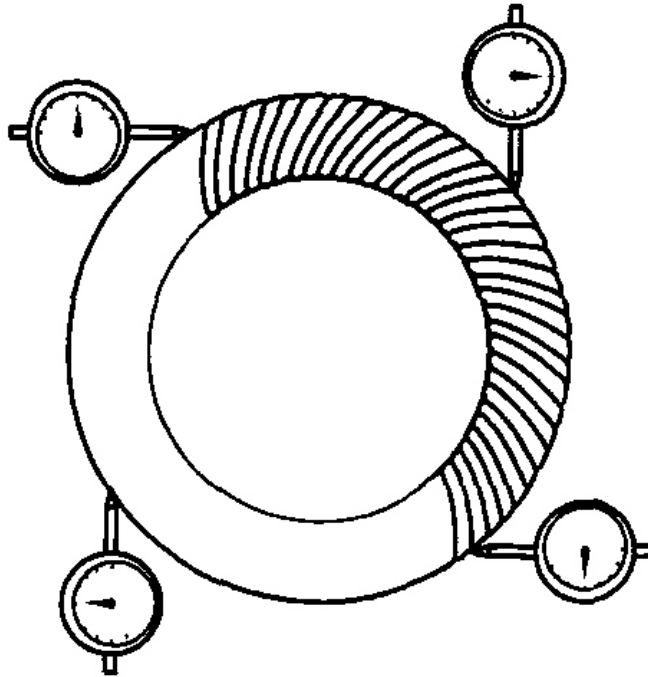

A6A63192036

Fig. 46: Measuring Backlash At 4 Locations Around Ring Gear
Courtesy of MAZDA MOTORS CORP.

9. If the backlash is not within the specification, adjust the gear case component by moving it in the axial direction.

NOTE:

- When moving the gear case component in the axial direction, replace the adjustment shims. If the adjustment shim on the right side is replaced with one that is 0.05 mm {0.0020 in} thicker, replace the one on the left with one that is 0.05 mm {0.0020 in} thinner.

BEARING CAP ASSEMBLY NOTE

1. Align the bearing cap alignment marks and assemble the bearing cap with the arrow facing outward.

Tightening torque

72.6-106.9 N.m {7.41-10.91 kgf.m, 53.5-78.84 ft.lbf}

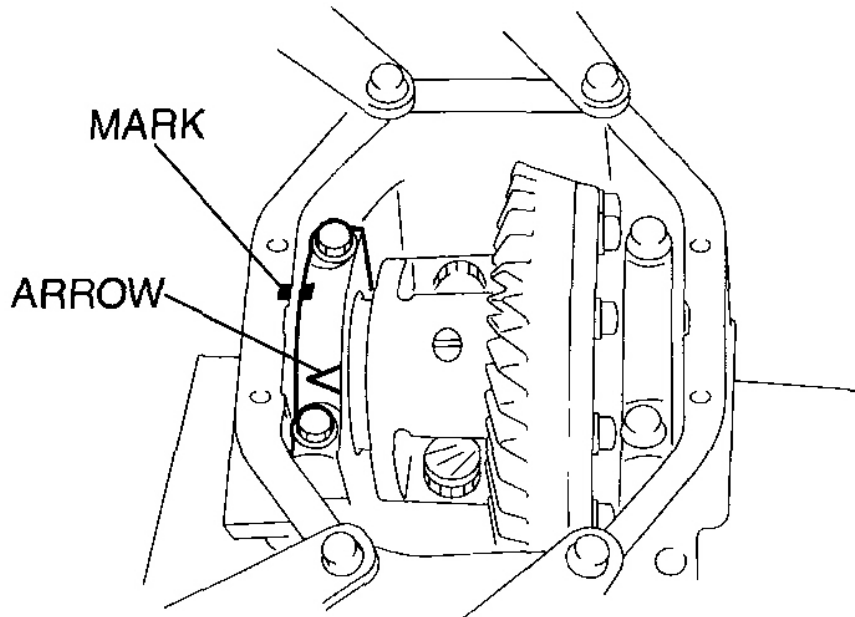

CHU0314W014

Fig. 47: Aligning Bearing Cap Alignment Marks & Assembling Bearing Cap
Courtesy of MAZDA MOTORS CORP.

2. Perform the drive pinion and ring gear tooth contact inspection.

DRIVE PINION, RING GEAR TOOTH CONTACT INSPECTION

1. Apply tooth marking compound evenly to both surfaces of the ring gear.
2. Rotate the ring gear back and forth for several times.
3. Inspect the tooth contact pattern in 4 locations around the ring gear, and verify that the tooth contact points exhibit the pattern shown in **Fig. 48**.
 - If the tooth contact points are normal, wipe off the marking compound.
 - If the tooth contact points are not normal, adjust the pinion height, then adjust the backlash.

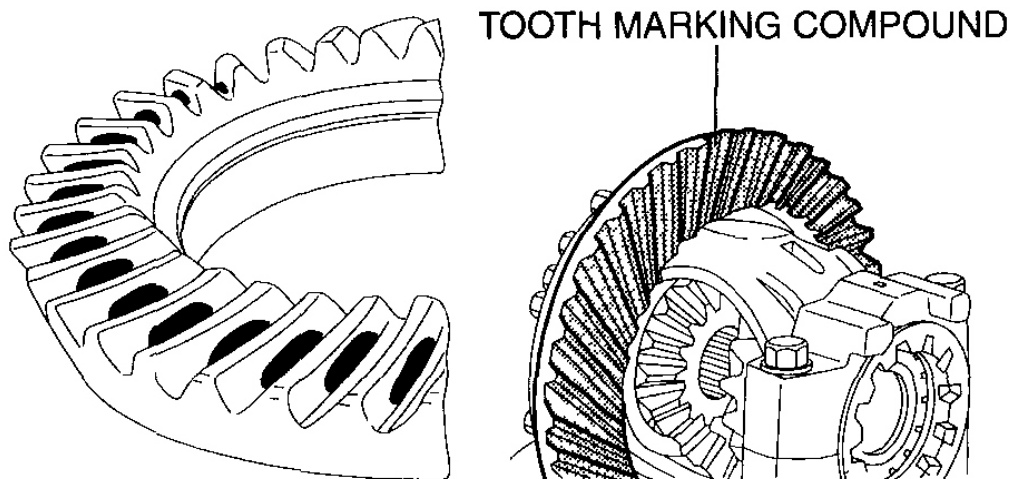

CHU0314W020

Fig. 48: Inspecting Tooth Contact Pattern In Locations Around Ring Gear
Courtesy of MAZDA MOTORS CORP.

4. If the toe and flank contact points appear as shown in **Fig. 49** after the drive pinion and ring gear teeth contact inspection, replace the spacer with a thinner one, and move the drive pinion outward.

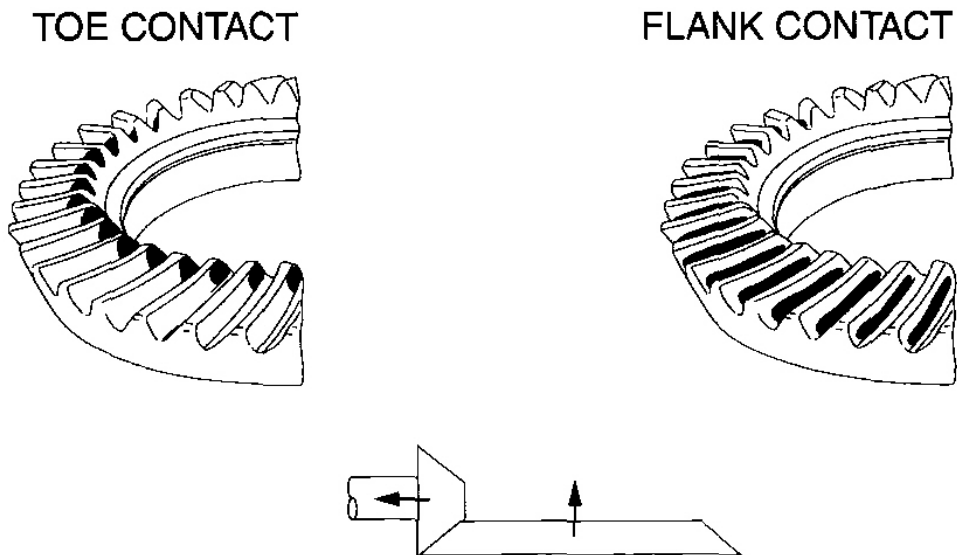

CHU0314W021

Fig. 49: Identifying Toe Contact & Flank Contact Points
Courtesy of MAZDA MOTORS CORP.

5. If the heel and face contact points appear as shown in **Fig. 50** after the drive pinion and ring gear teeth contact inspection, replace the spacer with a thicker one, and move the drive pinion inward.

HEEL CONTACT

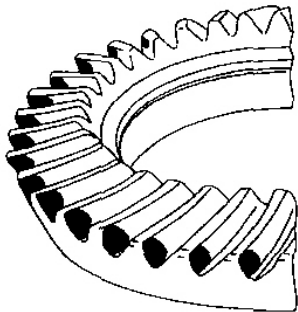

FACE CONTACT

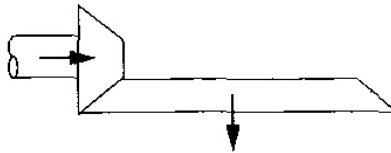
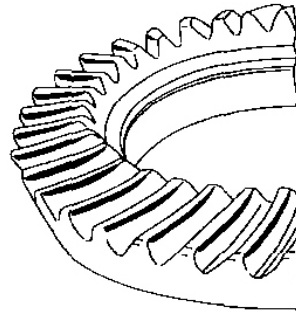

CHU0314W022

Fig. 50: Identifying Heel & Face Contact Points
Courtesy of MAZDA MOTORS CORP.